

ProVent®

Guide to Design and Usage

ProVent Single Stack System

Handling ■ Installation ■ Corrosion
Ease Simplicity Resistance

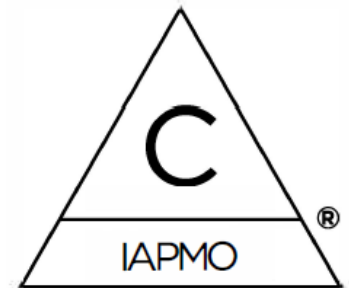

Copyright © 2025, Revision #7, ProVent Systems Inc., All Rights Reserved

ProVent Systems Inc. ■ 1355 Capital Circle ■ Lawrenceville ■ Georgia ■ 30043-5866
770-339-1782 ■ 800-262-5355 ■ Fax: 770-339-1784

■ www.ProVentSystems.com ■

ProVent System Components

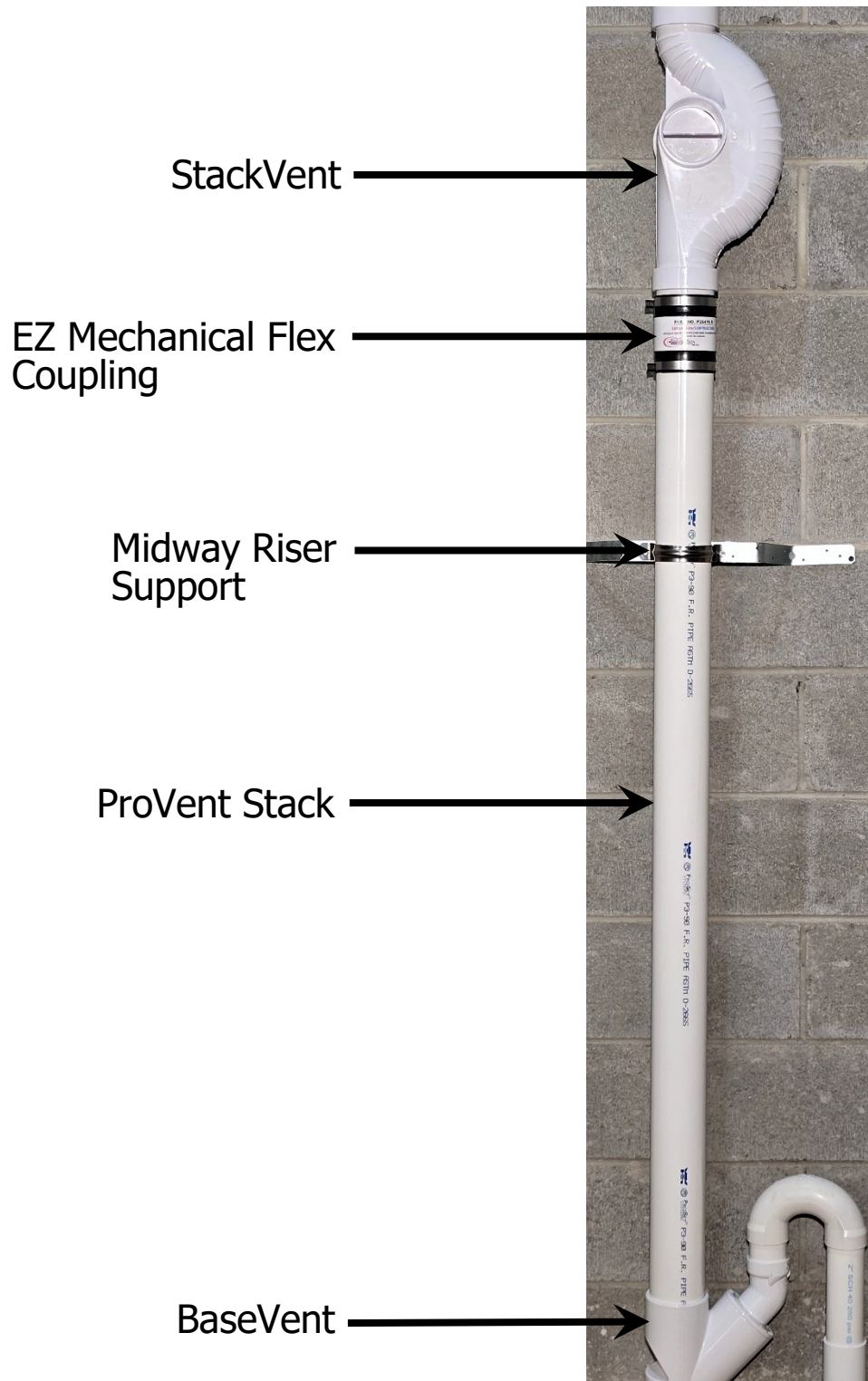



Table of Contents	
Wisconsin DSPS ProVent Systems	Page 4
Introduction to ProVent Systems	Page 5
Rules for ProVent Stacks and StackVent Fitting	Page 6
Rules for the ProVent BaseVent Fitting	Page 7
Rules for Branch Openings	Page 8
Chart 1: Fixture Unit Values by Type of Fixture	Page 9
Chart 2: Maximum Loading by Branch	Page 10
Chart 3: Maximum Loading by Stack	Page 10
Chart 4: Maximum Loading by Building Drain	Page 10
StackVent Dimensions	Page 11
BaseVent Dimensions	Page 12
Drawings to Illustrate Rules for Use of StackVent	Pages 13-23
Drawings to Illustrate Rules for Use of BaseVent	Pages 24-30
Drawings to Illustrate Rules for Branch Openings	Pages 31-36
Drawings 31a-f: Other Examples of ProVent Fixture Branches	Page 37
Drawing 32: Example of Side-by-Side Layouts	Page 38
Drawings 33 a-b: Example of Single Unit Layouts	Page 39
Drawings 34 a-c: Example of Back-to-Back Layouts	Pages 40-41



Wisconsin DSPS ProVent Systems 2022

SPS 382.20(8). REVISIONS. All changes or modifications, which involve the provisions of chapters SPS 382 to 384, made to ProVent Systems plumbing plans and specifications which have been granted approval under sub. (1), shall be submitted to the department or agent municipality for examination. All changes and modifications shall be approved in writing by the department or agent municipality prior to the installation of the plumbing.

SPS 381.01 Definitions. In chapters SPS 381 to 387 except as otherwise specifically defined:

Stack Vent Fitting. (Aerator) Used to control velocity of effluent in the sanitary waste stack.

ProSet Sleeve. Used to fire rate pipe penetration through concrete floors and wood assemblies.

BaseVent Fitting. (Deaerator) to control the hydraulic jump at the base of the stack.

EZ-Flex Coupling. Used to control the expansion & contraction within the PVC vertical stack.

Pressure Relief Line. Used as a relief vent from the Base Vent Fitting to its horizontal drain line.

Building Drain. Horizontal piping that is within or under a building installed below the lowest fixture or the lowest floor level from which fixtures can drain by gravity to the building sewer. Building drain sanitary means a building drain which conveys waste water consisting in part of domestic wastewater.

Horizontal Drain. A fixture drain which is individually connected to a building drain.

Revent Connection. A conventional sanitary plumbing vent tied back into a ProVent vertical stack.

Soil Branch. Discharge from any fixture, appliance, area, or appurtenance.

Waste Branch. Discharge from any fixture, appliance, area, or appurtenance.

Free ProVent Installation approved training available call 1-800-262-5355

All installing plumbers shall be factory trained and carry a ProVent ID card indicating successful completion of factory authorized training prior to installing ProVent Single Stack systems.

SPS 382.20(12)(a). ProVent single stack systems shall be installed per specific conditions imposed during the alternate approval process. See **DSPS PTO # PP-022500001-PTOAA**. All changes or modifications to the ProVent system, shall be submitted to the department for examination. All changes and modifications shall be approved in writing by the department or agent municipality prior to installation of the plumbing. Per the Alternate Product approval letter only the ProVent manual located on the DSPS website shall be used for design and installation.





Introduction to ProVent® Systems

A PVC Plastic Single Stack Waste and Vent System

The ProVent System® is a plumbing engineered single stack system that finally offers the industry a PVC equivalent to the cast iron Sovent® system. Introducing the ProVent Stack Fitting® and the ProVent Base Fitting®. This major change from cast iron fittings allows the installation of a complete PVC single stack drainage and vent system.

If you use PVC but you want the benefits of a Sovent®-style system, you can now use the ProVent System. Also, because the ProVent System is not subject to corrosion, you can safely use it in coastal regions.

The ProVent System® is particularly effective in multi-story buildings such as hotels, condos, and apartments where it creates considerable cost savings as well as enhanced performance and longevity. It increases the capacity of the plumbing stack, eliminates separate vent piping, and minimizes pipe penetrations.

The ProVent Stack and the ProVent Base Fittings reduce the maximum flow velocity, increase the stack waste water capacity, and control the interior air pressures that can cause siphonage and blowout of fixture traps.

ProVent Systems® Fittings were designed to further enhance acoustic performance by increasing wall thicknesses and providing sound absorbing ribs that greatly reduces the water noise associated with plastic piping. This new system creates a sound-tested "Whisper-Quiet PVC Plumbing System".

This type of single stack system has been used for over forty years, with proven performance throughout the world. In addition to these proven benefits, the ProVent System provides the following:

Flexible couplings that connect the piping from the Base to the Stack Fitting provide for a pipe expansion and contraction system that works.

A StackVent system that fits plumbing walls and will fit drop ceilings without requiring special recess boxes.

Easier installation due to its light weight (7.5 pounds) and elimination of the need for hangers (when used with ProSet Systems fire-rated penetrations) .

The plumbing approvals for using this new system are granted under the Alternate Materials & Methods or the Alternate Professional Engineers Design criteria in the Plumbing Codes based on ASSE 1043, ASTM D-2665, and NSF 14 Test & Design Standards.

If the ProVent System, as defined under **WIS PTO #: "PP-022500001-PTOAA"**, is modified or additional assertions of function or performance are made, the approval shall be considered null and void, unless the change is submitted to the department for review and the approval is reaffirmed.



1. Rules for the ProVent® Stack and StackVent Fitting

Note: The Charts referred to below are contained on pages 8 and 9.

1.1 The ProVent stack must be sized by the total number of fixture units (D.F.U.) discharging into it. Chart 1 provides the number of fixture units by individual fixture. The sum of the fixture units for all fixtures discharging into the stack equals the total fixture units. Chart 3 provides the required stack size by total fixture units. The stack size shall continue full size through the roof.

1.2 A ProVent Stack Fitting is required to be used at each floor level when the horizontal soil or waste branch collected is either the same size or one pipe size smaller than the vertical ProVent Stack Fitting. When the stack size is 3" and the Base Vent Fitting and Cleanout is 4", this vertical portion of piping is not considered a reduction to the 3" stack but as an enlargement of the stack and is acceptable.

1.3 Waste branches that are two (2) pipe sizes smaller than the stack can be connected with a sanitary tee or wye directly into the ProVent stack (between ProVent Stack Fittings).

1.4 If there are no branch connections at a floor level, there is no need to use the ProVent Stack Fitting. Instead, a double in-line offset must be used in its place. The vertical interval between the Stack Fitting and the in-line offset shall not exceed 20 feet and no more than two (2) consecutive double in-line offsets can be used.

1.5 Offsets in the stack of more than 60 degrees require a ProVent Base Fitting with a pressure relief vent line tied in to the top vertical portion of the stack. Branch piping can be connected to the offset soil piping above the centerline of the main drain. The offset piping shall be sized by chart 4 using all fixture units discharging above the offset, this may require resizing the stack. A 45 degree stack offset is not considered an offset. Waste branches (1) one pipe size smaller can be connected to the pressure relief vent line with the exception of washing machine wastes. All new front load washing machines use HE laundry detergents that no longer create sudsing problems eliminating the need to isolate its stacks. All pressure relief lines require a cleanout per SPS 382.35(6).

1.6 The drain size of horizontal offsets greater than 60 degrees is determined by the total fixture unit load shown in chart 4 discharging upstream of the offset.

1.7 Stacks may offset above the highest fixture served. When the horizontal offset exceeds twenty (20) feet, the diameter of the horizontal offset and the vent through the roof must be increased one pipe size

1.8 Combinations of vent stacks may be tied together above the highest fixture served before going through the roof. The combined vertical stack must be increased (1) one pipe size larger than the combined stacks. If the distance between the two (2) stacks that connect is greater than twenty (20) feet, the horizontal branch must be one (1) pipe size larger than the downstream stack. Sizing for three or more combined vent headers is based on the cumulative DFU total from each stack and capacities in the Multiple Header Ratings chart on page 17.

1.9 An additional stack may be connected to another ProVent vertical stack by using a wye and 1/8 bend in-between a Base Fitting and a wye in the main stack for the PRL line. Sizing of the branch is made by the DFUs upstream from the connection. Sizing of the main ProVent stack is made by the total DFUs from the combination of both stacks. The PRL from the BaseVent must be tied back into the run of the drain.

1.10 Additional stacks may be connected to a ProVent stack by using a wye and 1/8 bend for one stack and a 1/4 bend for the other. The PRL from one of the BaseVents must be tied into the vertical stack; the other can be tied in above the centerline in the horizontal drain. Sizing of the offsets and stacks are made by the total DFUs draining into them.

1.11 (Optional) Plastic pipe expansion and contraction shall be provided in all buildings exceeding 3 stories. The ProSet solvent cemented firestop couplings will restrain pipe movement between the floors. The EZ Mechanical Flex Coupling allows 1/2" up or down movement in-between each floor. The two-step anchor and flex combination controls plastic DWV pipe expansion and contraction within a building of any height.



2. Rules for the ProVent® BaseVent Fitting

Note: The Charts referred to below are contained on pages 8 and 9.

2.1 A ProVent Base Fitting must be installed at the base of each vertical stack before it enters the horizontal building drain. If the vertical distance to the closest ProVent Stack Fitting exceeds twenty feet (20'-0") an inline offset must be installed within five feet (5'-0") above the ProVent Base Fitting. The building drain size is calculated by using Chart 4 in accordance with the fixture unit values (D.F.U.) for all fixtures discharging into it as shown in Chart 1.

2.2 The ProVent Base Fitting has a pressure relief vent opening that extends up then makes a 180 degree turn downward using pipe and fittings that connect to the horizontal building drain at a point no less than 10 pipe diameters downstream from the center line of the vertical stack to the centerline of the branch wye. The pressure relief vent line may run parallel to the horizontal drain and must connect at an angle 45° or greater above the centerline of the drain.

2.3 A ProVent Base Fitting must be used on any stack offsets within the stack of more than 60 degrees with the pressure relief vent connection running from the base fitting back into the vertical drop portion of the stack. A cleanout is required at the base of the stack. When there are no fixture openings taken off the horizontal building drain, a cleanout must also be added to the vertical PRL line.

2.4 Soil and waste branches can be connected into the building drain between the stack and the relief vent when the connections are made above the center line of the building drain. Above centerline branch connections are not required when branches are made a minimum of 40 inches downstream from the centerline of the stack and upstream from the PRL. Branch loading should be in accordance with Chart 2.

2.5 Waste branches at least (1) one pipe size smaller can be connected to the pressure relief horizontal vent line. No waste branch is allowed to connect to the 2" PRL. No connections should be made into the vertical portion of the PRL.

2.6 Soil or waste branches may connect directly into the vertical stack directly below the ProVent Base Fitting only when the connections are made using fittings such as a combination wye and 1/8 bend.

2.7 Soil or waste branches can connect downstream from the pressure relief vent to pick up remote conventional plumbing fixtures. Conventional plumbing vents can tie directly back into the ProVent vertical stack below the stack fitting using an upright wye and 1/8 bend. Vent sizing is based on the additional fixture units or the vents can be separately vented through the roof in accordance with locally accepted plumbing code venting methods and sizing.

Note: The corresponding drawings are shown as examples of the rules. However, there may be other options not shown in the drawings.



3. Rules for **Branch Openings**

Note: The Charts referred to below are contained on pages 9 and 10.

Note: The corresponding drawings are shown as examples of the rules. However, there may be other options not shown in the drawings.

3.1 All branch piping sizes and loads should be in accordance with Chart 1. Branch piping should have a minimum of 1/8" per foot pitch.

3.2 Changes in direction on horizontal branches by 90° shall be made with two (2) forty five degree fittings or a long turn 90 degree fitting.

3.3 If two (2) 3.5 gpf public water closets are connected to the same branch, the first connection can be 3" then increased to 4" at the second connection. This increase is not required for the 1.6 gpf low flow flush water closets. Check manufacturers installation instructions for pressure assisted type water closets or large flush valves that may require special fittings or spacing requirements for back to back installations.

3.4 4" Size branches shall not exceed a developed length of 27 feet. 3" Size branches shall not exceed a developed length of 15 feet. 2" Size branches shall not exceed a developed length of 15 feet. These lengths include any horizontal pipe offsets but the length of the vertical drop arms is not included (see Rule 3.5 for restrictions on vertical drops). Horizontal to horizontal branch connections should be made with wye type fittings.

3.5 Vertical branches should not exceed 40". A 45 degree offset can extend the drop pipe to 40" from the top 45 degree fitting to the fixture outlet. When a vertical drop into a horizontal waste exceeds 10 feet both must increase one (1) pipe size.

3.6 1-1/4" size fixture traps can be connected back to back into one 2" vertical drop. A maximum of (2) 1-1/2" size fixture traps serving the same fixture may be served by (1) 2" vertical drop. Larger traps can use a single vertical drop by increasing the drop one (1) pipe size. Horizontal waste branches without vertical drops are sized per chart 2.

Special Note: ProVent systems recommends and designs washing machine connections to serve washing machines which require the use of no sudsing high efficiency detergents.

3.7 An alternate to increase developed lengths can be done by using a revent line or by telescoping smaller to larger pipe sizes or by using an Air Admittance Valve where applicable and permitted. The revent line shall be routed vertically and horizontally and tie in above the flood rim level using a wye branch looking up.



Chart 1: Fixture Unit Values Using Water Saving Fixtures

<i>Fixture</i>	<i>Fixture Units</i>
Bathrooms	
Water Closet: Flush Valve	6
Water Closet: Tank Operated	3
Urinal: Pedestal	6
Urinal: Non-Pedestal	2
Bidet	2
Bathtub (with or w/o shower), Spa Tub	2
Shower (per showerhead)	2
Lavatory	1
Bathroom Group 1: Lavatory, Bathtub (with or w/o shower), Flush Valve Water Closet	8
Bathroom Group 2: Lavatory, Bathtub (with or w/o shower), Tank Operated Water Closet	4
Kitchens	
Sink (with disposal with or w/o dishwasher connection)	2
Sink (scullery)	2
Residential Dishwasher	2
Laundry Room	
Washing Machine	2
Laundry Tray (One or Two Compartments)	2
Specialty Fixtures	
Sink: Flushing Rim with Valves	6
Sink: Service (P-Trap)	2
Sink: Service (Standard Trap)	3
Lavatory: Surgeon	2
Lavatory: Hairdresser, Beauty Parlor	2
Miscellaneous	
Floor Drain, Floor Sink, Mop Sink, Trench Drain: 2"	2
Floor Drain, Floor Sink, Mop Sink, Trench Drain: 3"	3
Floor Drain, Floor Sink, Mop Sink, Trench Drain: 4"	4
Drinking Fountain	1
Clinic Service Sink	6
Commercial Dishwasher	4
Hub Drain Receptor: 2"	2
Hub Drain Receptor: 3"	4
Hub Drain Receptor: 4"	6



Maximum Loading by Branch, Stack and Building in Fixture Units

Chart 2: Maximum Loading by Branch

Chart 3: Maximum Loading by Stack

Drain Size	Slope 2% (1/4" per foot)	Slope 1% (1/8" per foot)
	Fixture Units	Fixture Units
2"	6	5
2½"	12	9
3"	16	13
4"	90	72

*Only two water closets may be connected to a common 3" soil branch. Increase one pipe size when downstream fixtures are added

Stack Size	Fixture Units
3"	64
3" (over 7 stories)	102
4"	504
5"	1,010
6"	2,200
8"	3,900

*12 water closets are permitted into a 3" stack when using a 4" building drain.

Chart 4: Maximum Loading by Building Drain

Drain Size	Slope 2% (1/4" per foot)	Slope 1% (1/8" per foot)
	Fixture Units	Fixture Units
3"	42	36
4"	216	180
5"	350	280
6"	850	680
8"	2,700	2,160
10"	3,900	3,120
12"	5,800	4,640

*This table also applies to stack offsets, base fittings, and PRL lines for the combined load of fixture units upstream from the offset.



StackVent Dimensions

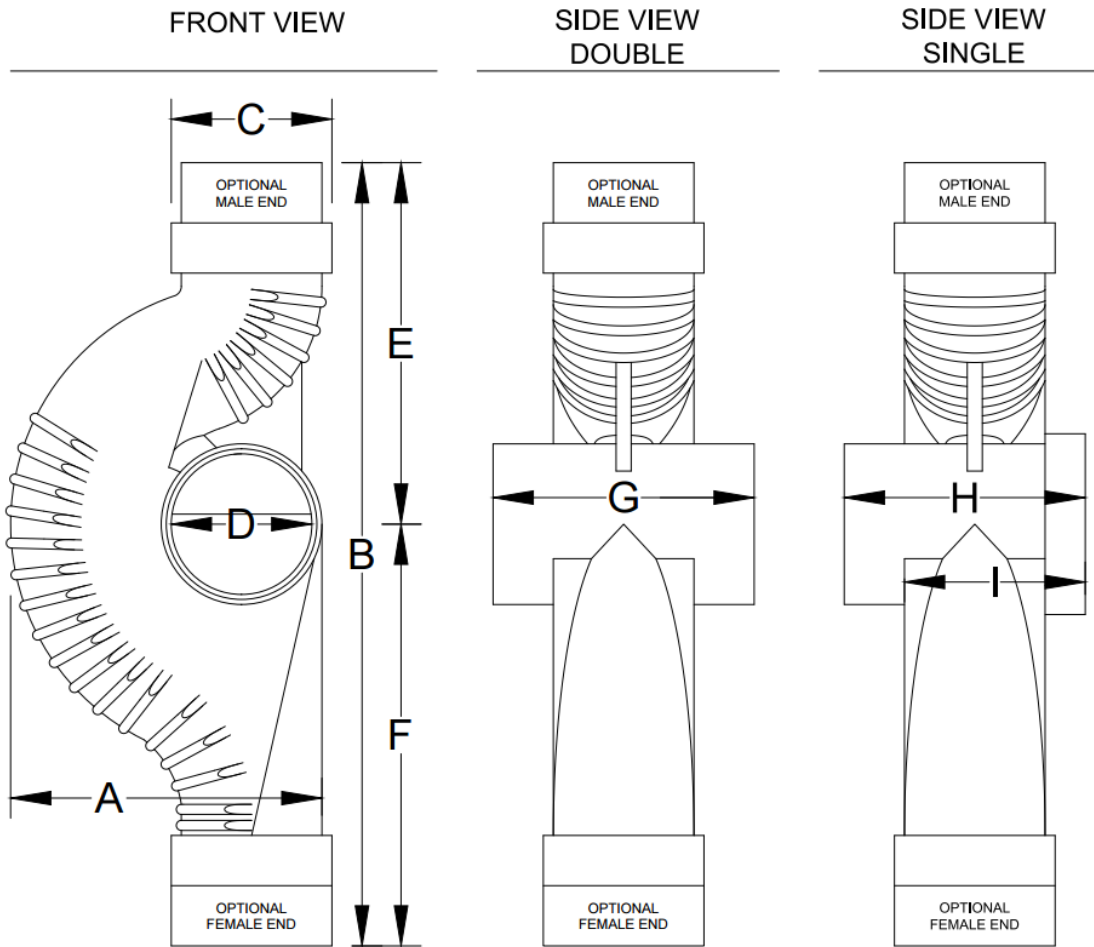

	A	B*	C	D	E*	F	G	H	I
3"	7-3/4"	19-1/4"	3-1/2"	3-1/2"	9"	10-1/4"	6-1/2"	5-3/4"	4-1/4"
4"	9-3/4"	23-3/4"	4-1/2"	4-1/2"	10-3/4"	13"	8"	7"	5-1/4"

*Stack fitting can be ordered with optional mixed male or female ends

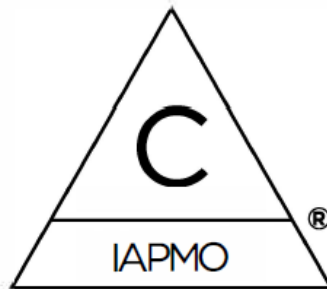

BaseVent Dimensions

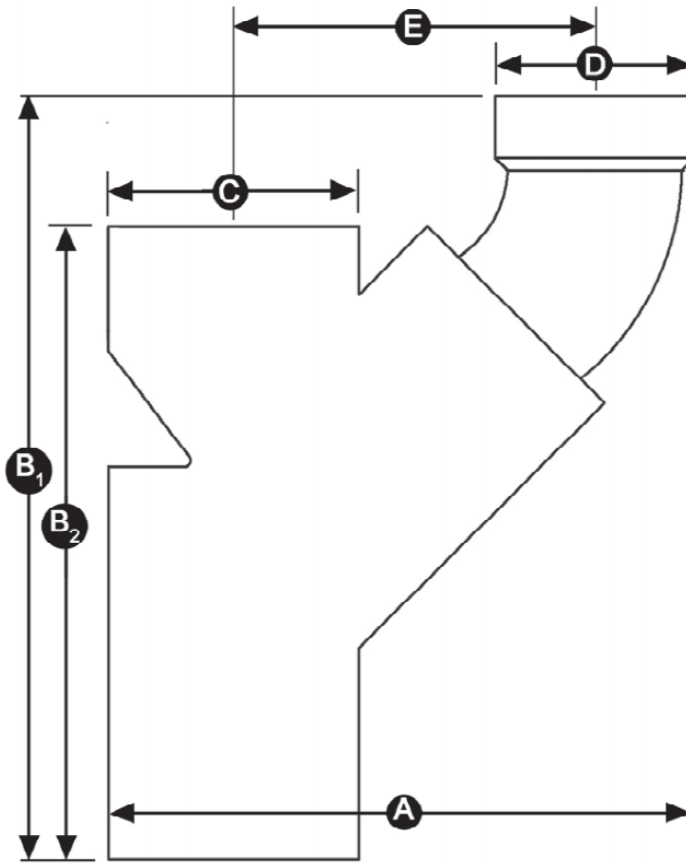

	A	B₁	B₂	C	D	E
3" x 2"	9-1/2"	11"	9-1/4"	4"	2-3/4"	6"
4" x 3"	11-1/2"	13-1/2"	11"	5"	4"	7"

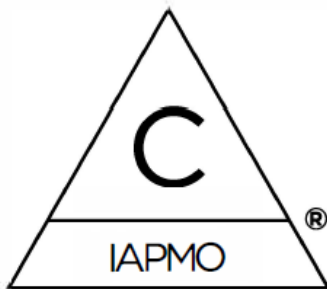

Stack and StackVent Fitting Rule 1.2

A ProVent Stack Fitting is required to be used at each floor level when the horizontal soil or waste branch collected is either the same size or one pipe size smaller than the vertical ProVent Stack Fitting. When the stack size can be 3" and the Base Vent Fitting and Clean Out is 4", this vertical portion of piping is not considered a reduction to the 3" stack but as an enlargement of the stack and is approved.

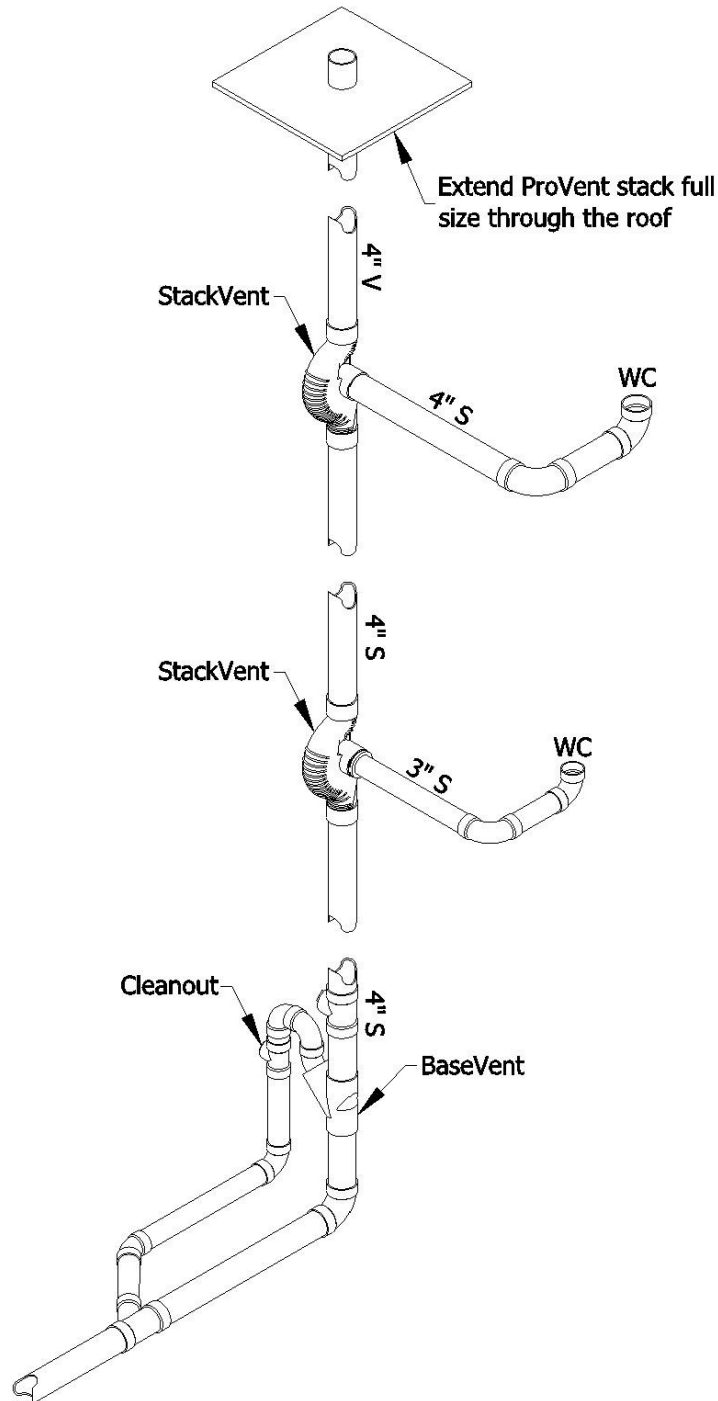

Drawing 1.2



Stack and StackVent Fitting Rule 1.3

Waste branches that are two (2) pipe sizes smaller (2½" included) than the stack can be connected with a sanitary tee or wye directly into the ProVent stack (between ProVent Stack Fittings).

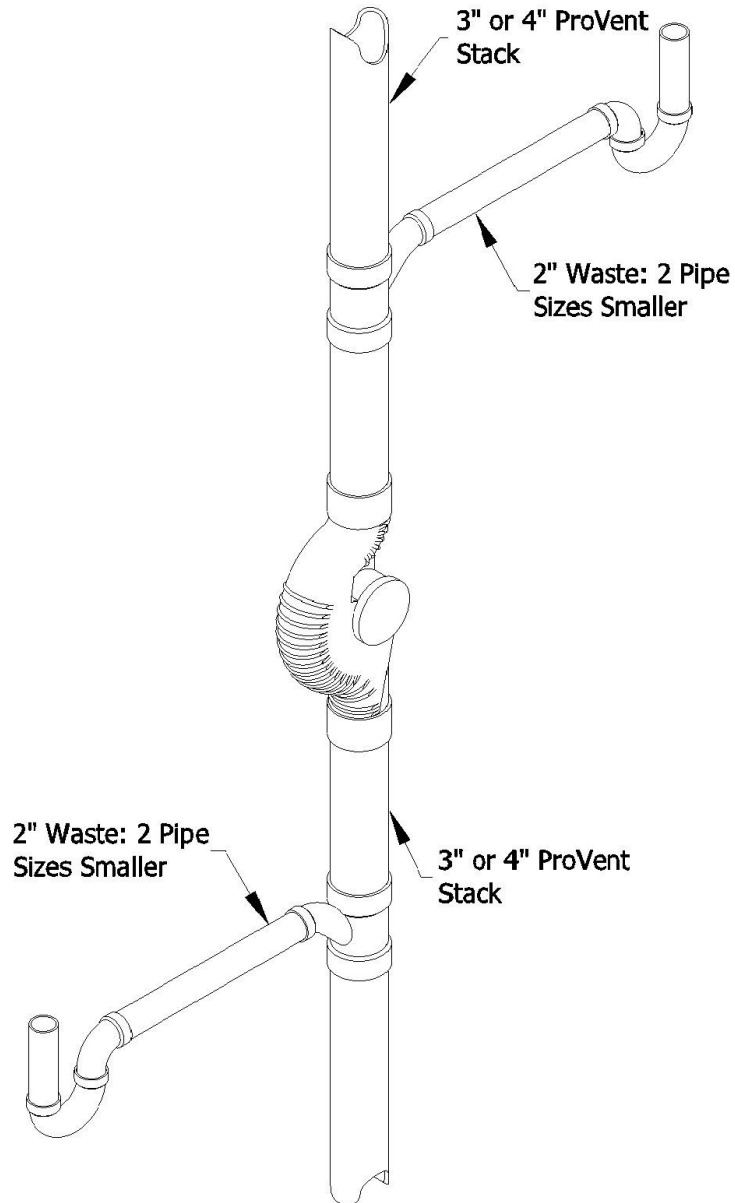

Drawing 1.3



Stack and StackVent Fitting Rule 1.4

If there are no branch connections at a floor level, there is no need to use the ProVent Stack Fitting. Instead, a double in-line offset must be used in its place. The vertical interval between the Stack Fitting and the in-line offset shall not exceed 20 feet and no more than two (2) consecutive double in-line offsets can be used. When a conventional stack starts at the lowest level in a building, then travels up through vertical areas like parking decks of twenty feet or more, and is the same size as the ProVent stack, it should use an inline offset every twenty feet until the stack turns into a ProVent horizontal collection system. If the conventional stack riser is larger than the ProVent stack, no inline offsets are required.

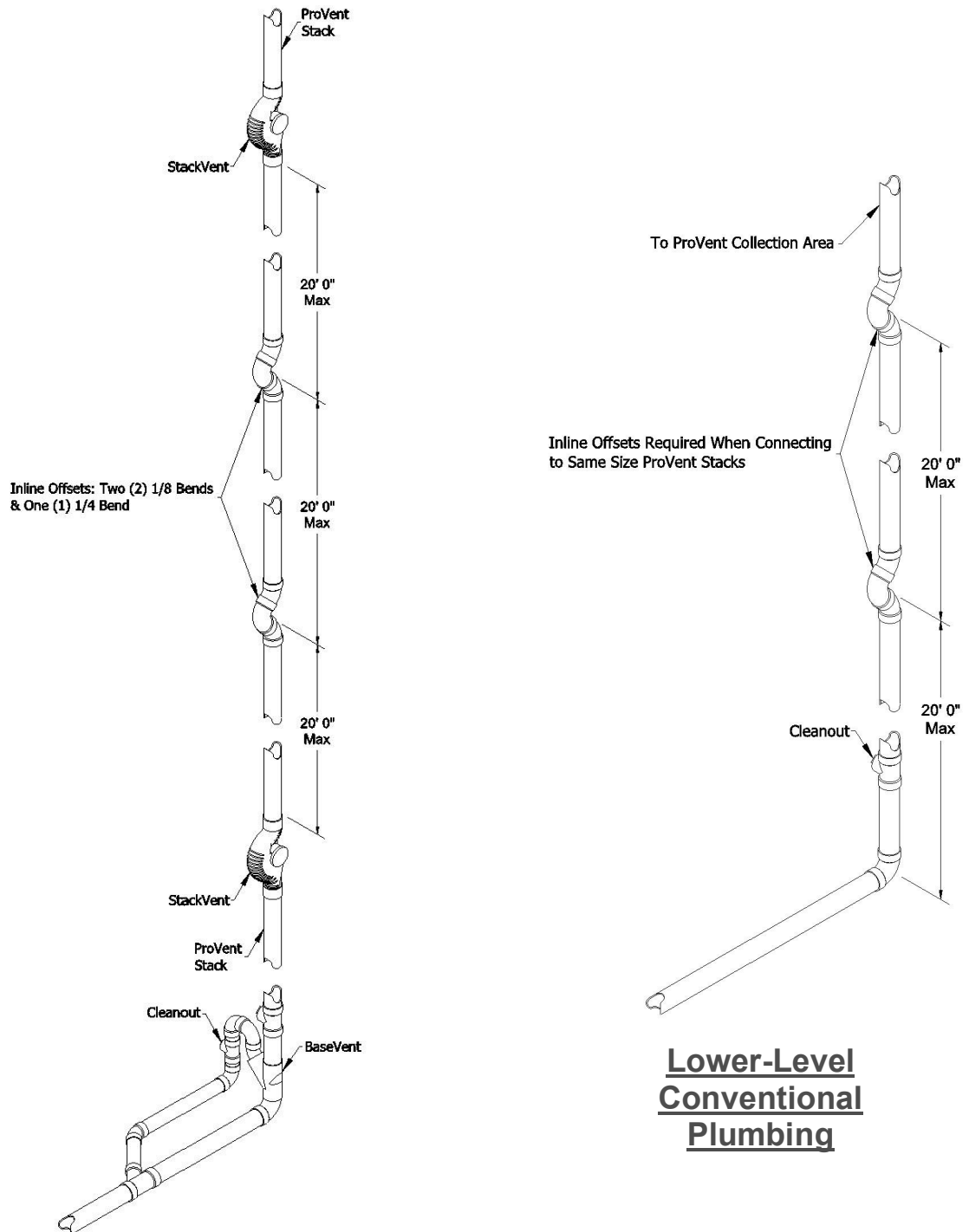

Drawing 1.4



Stack and StackVent Fitting Rule 1.5

Offsets in the stack of more than 60 degrees require a ProVent Base Fitting with a pressure relief vent line tied into the top vertical portion of the stack. Branch piping can be connected to the offset soil piping above the centerline of the main drain. The offset piping shall be sized by chart 4 using all fixture units discharging above the offset, this may require resizing the stack. A 45 degree change in direction is considered vertical and not an offset. Waste branches (1) one pipe size smaller can be connected to the pressure relief vent line with the exception of washing machine wastes. All new front load washing machines use HE laundry detergents that no longer create sudsing problems eliminating the need to isolate its laundry stacks. All pressure relief lines require a cleanout per SPS 382.35(6).

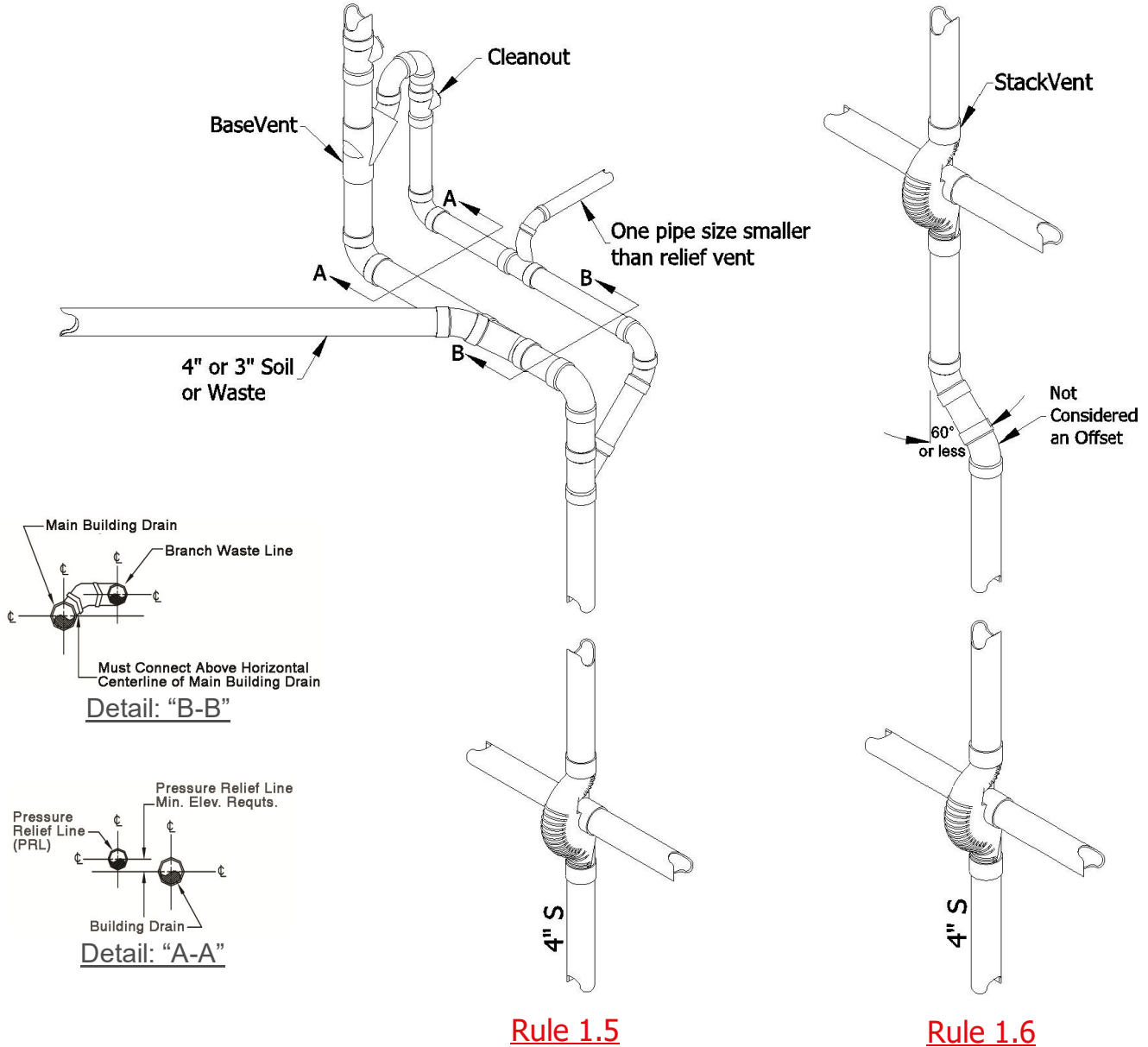

Stack and StackVent Fitting Rule 1.7

Stacks may offset above the highest fixture served. When the horizontal offset exceeds twenty (20) feet, the diameter of the horizontal offset and the vent through the roof must be increased one pipe size.

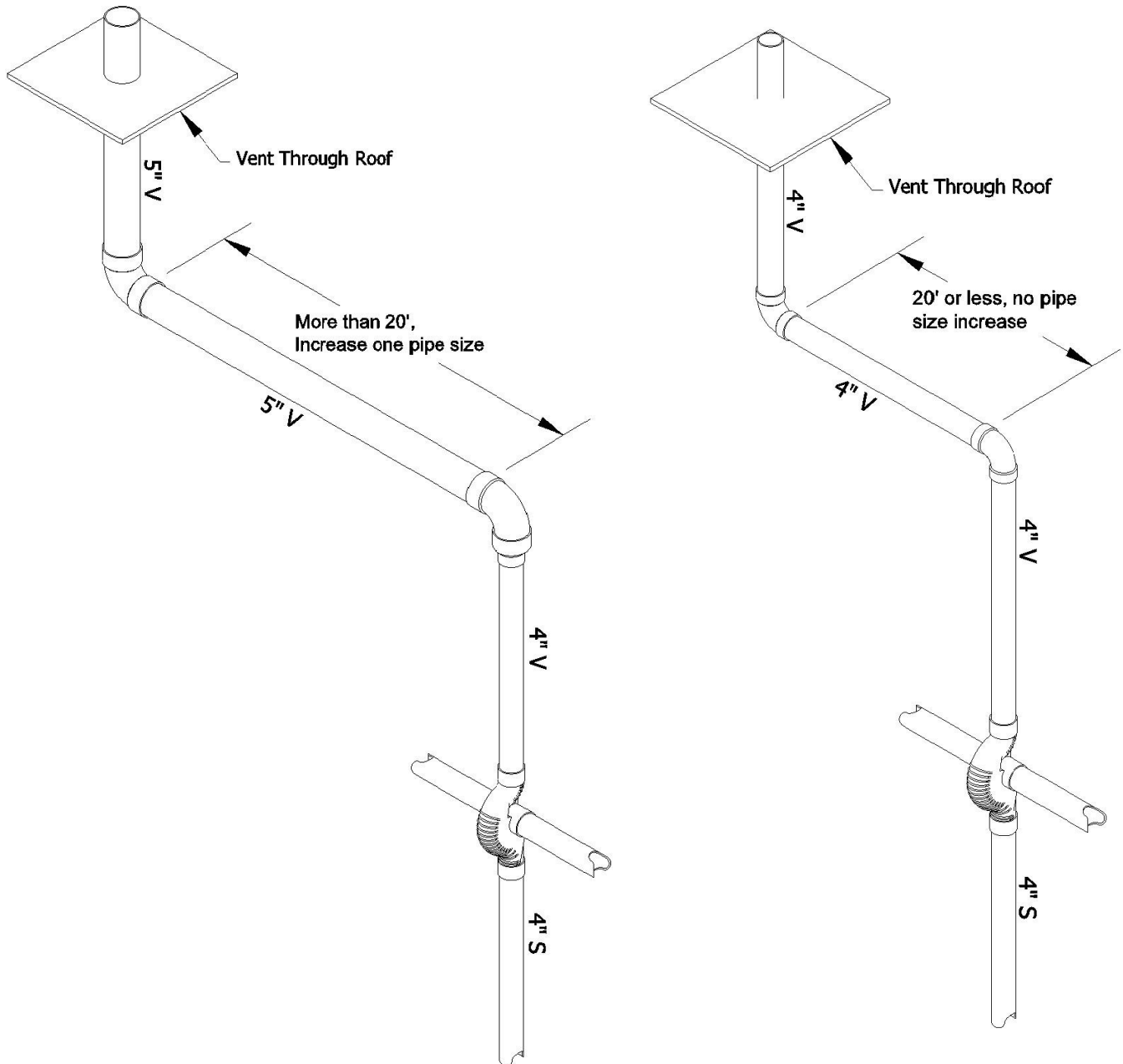

Drawing 1.7



Stack and StackVent Fitting Rule 1.8

Combinations of vent stacks may be tied together above the highest fixture served before going through the roof. The combined vertical stack must be increased (1) one pipe size larger than the combined stacks. If the distance between the two (2) stacks that connect is greater than twenty (20) feet, the horizontal branch must be increased one (1) pipe size larger than the downstream stack. Sizing for three or more combined vent headers is based on the cumulative DFU total from each stack and capacities in the Multiple Header Ratings table below.

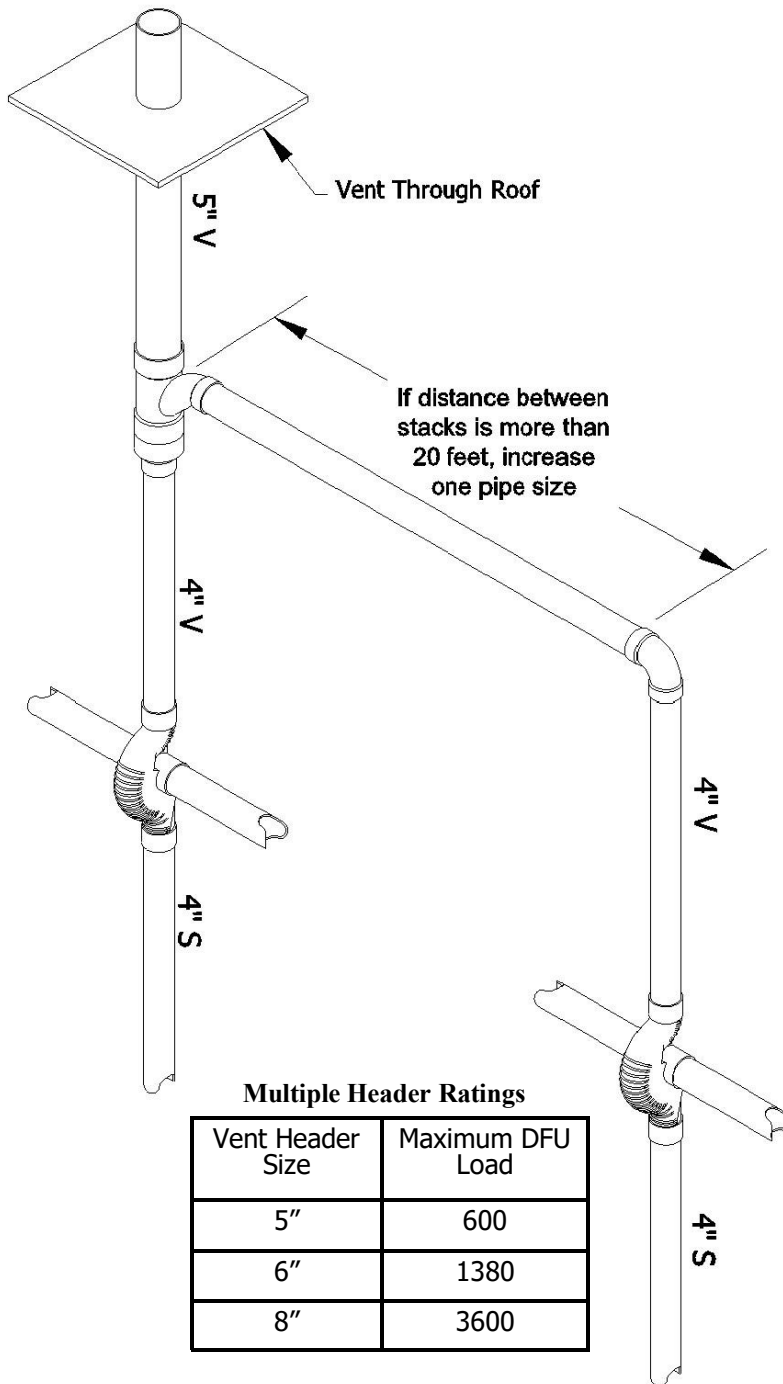

Drawing 1.8



Stack and StackVent Fitting Rule 1.9

An additional stack may be connected to another ProVent vertical stack by using a wye and 1/8 bend in-between a Base Fitting and a wye in the main stack for the PRL line. Sizing of the branch is made by the DFUs upstream from the connection. Sizing of the main ProVent stack is made by the total DFUs from the combination of both stacks. The PRL from the Base Vent must be tied back into the run of the drain.

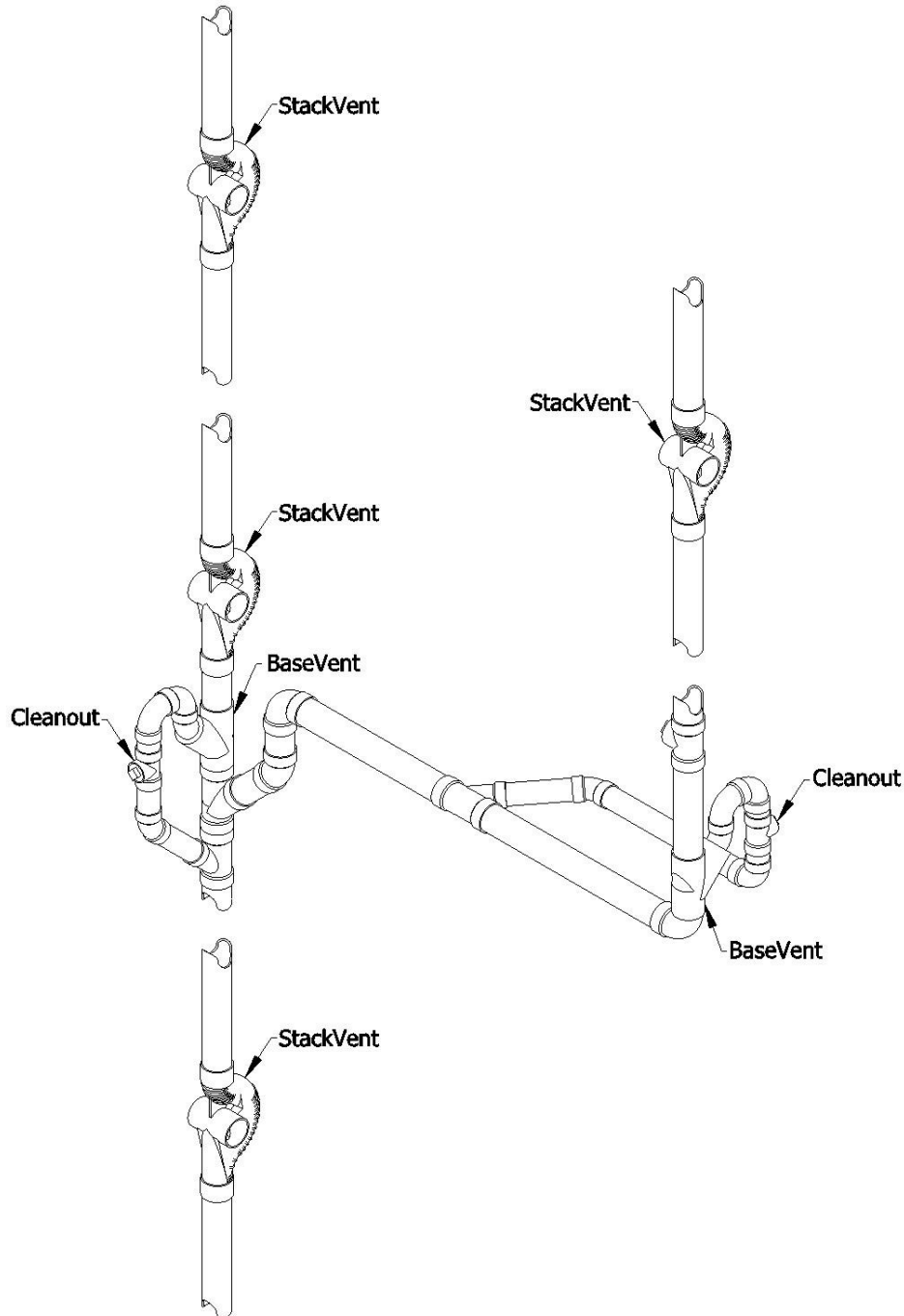

Drawing 1.9



Stack and StackVent Fitting Rule 1.10A

Additional stacks may be connected to a ProVent stack by using a wye and 1/8 bend for one stack and a 1/4 bend for the other. The PRL from one of the BaseVents must be tied into the vertical stack; the other can be tied in above the centerline in the horizontal drain. Sizing of the offsets and stacks are made by the total DFUs draining into them.

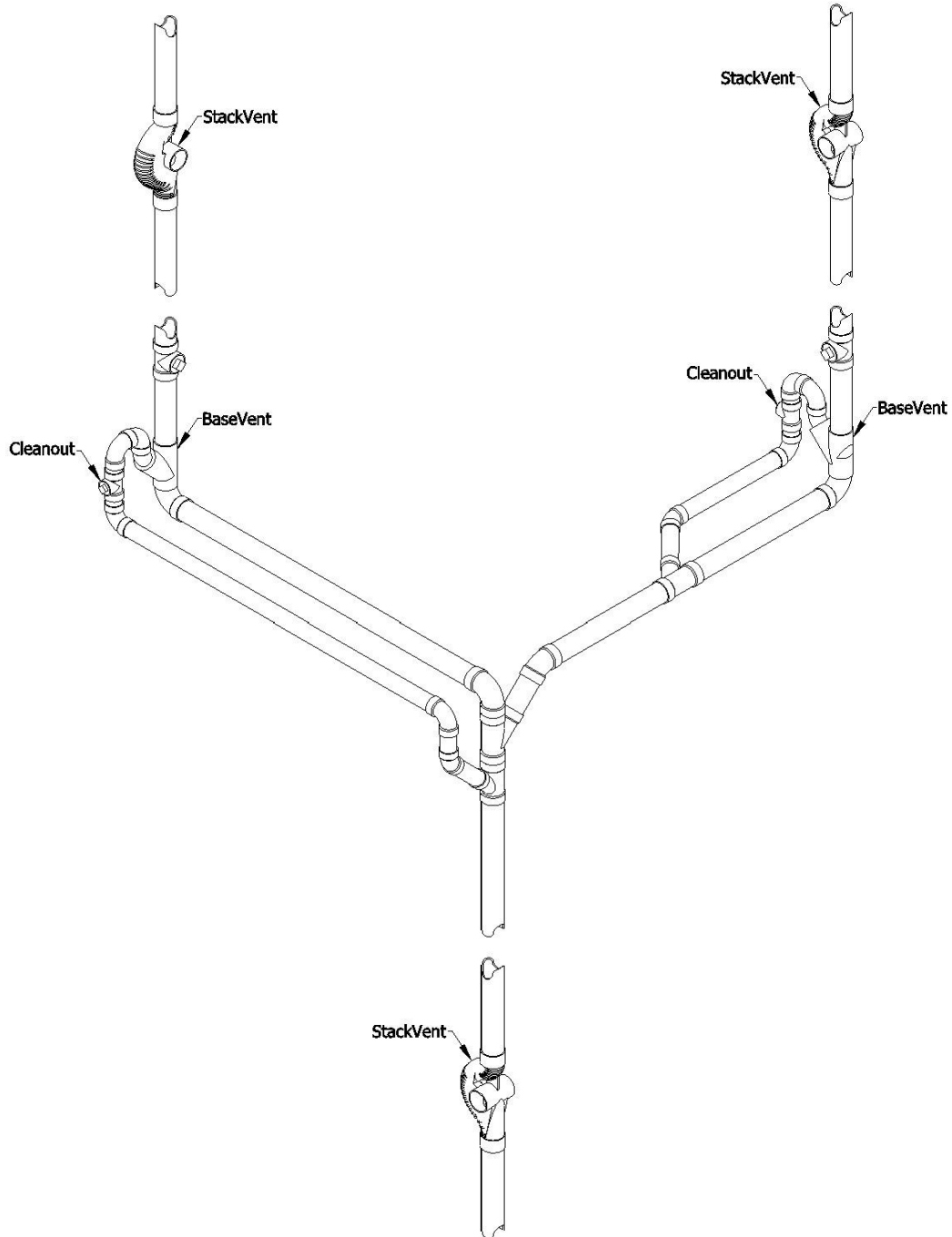

Drawing 1.10A



Stack and StackVent Fitting Rule 1.10B

Additional stacks may be connected to a ProVent stack by using a wye and 1/8 bend for one stack and a 1/4 bend for the other. The PRL from one of the BaseVents must be tied into the vertical stack; the other can be tied in above the centerline in the horizontal drain. Sizing of the offsets and stacks are made by the total DFUs draining into them.

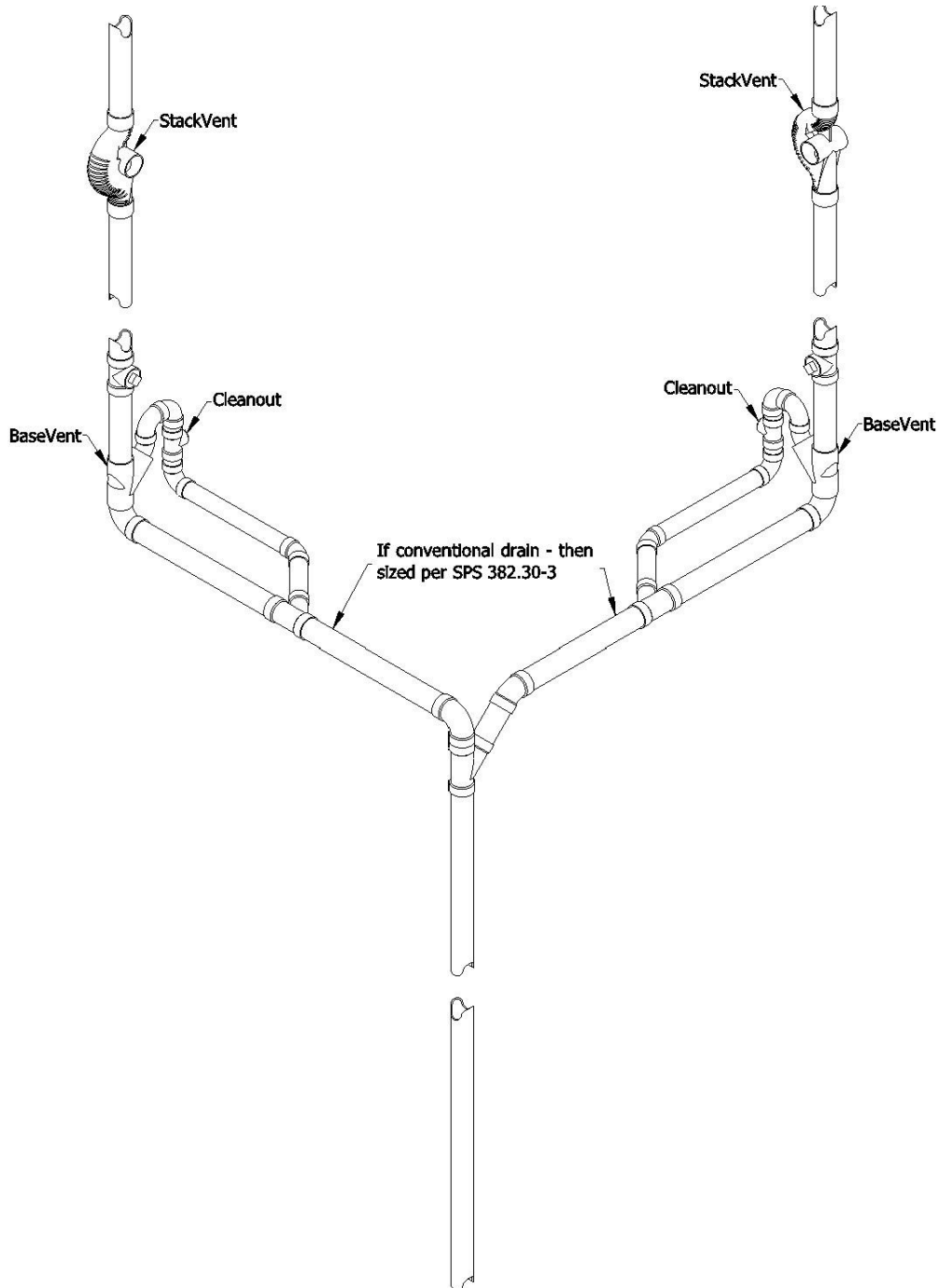

Drawing 1.10B



Stack and StackVent Expansion/Contraction 1.11

Plastic pipe expansion and contraction shall be provided in all buildings exceeding 3 stories. The ProSet solvent cemented firestop couplings will restrain pipe movement between the floors. The EZ Mechanical Flex Coupling allows 1/2" up or down movement in-between each floor. The two-step anchor and flex combination controls plastic DWV pipe expansion and contraction within a building of any height. Install EZ Mechanical couplings per manufacturers instructions.

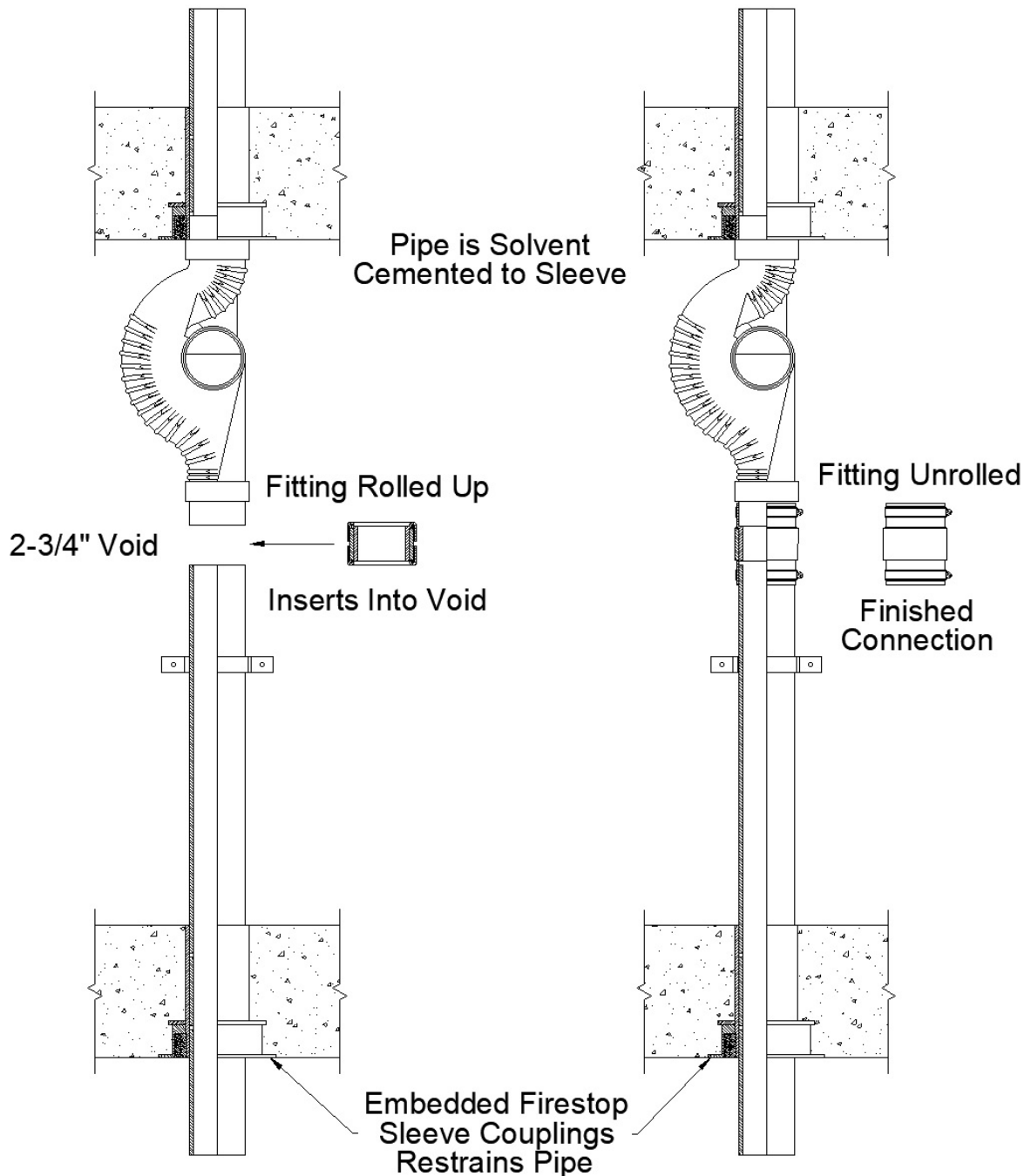

Drawing 1.11



EZ Mechanical Flex Installation Instructions

ProVent Expansion Joint



P35470-D—P45470-D

Installation Instructions:

The EZ Flex Mechanical Expansion Coupling is made to fit inside the 2-3/4" open space between the two connecting pipes. The engraved letters shown on the top part of the coupling also shows the top of the expansion joint. This allows the waste water to flow directly from the top side down into the stack.

Both ends of the coupling can be rolled down in order to fit inside the 2-3/4" space. The rolled back coupling can then be unrolled back onto the two connecting pipes. Adjust the coupling equally between the open spaces, then tighten the two stainless steel clamps using a 60 lb torque wrench.

Important:

An anchor must be used mid-point inside the wall to keep both pipes in alignment. Riser clamps must be used on both the top and bottom where the stack passes through the floors. A ProSet #49 Firestop sleeve coupling can be cast into the concrete floor as an alternative to using riser clamps. See other options of anchoring in the right-side drawing.

Because of unknown structural settlements plus normal expansion, ProVent recommends using one coupling at every floor level. Other floor locations may be used if approved by a structural engineer or the Building Inspector.

Typical ProVent Stack

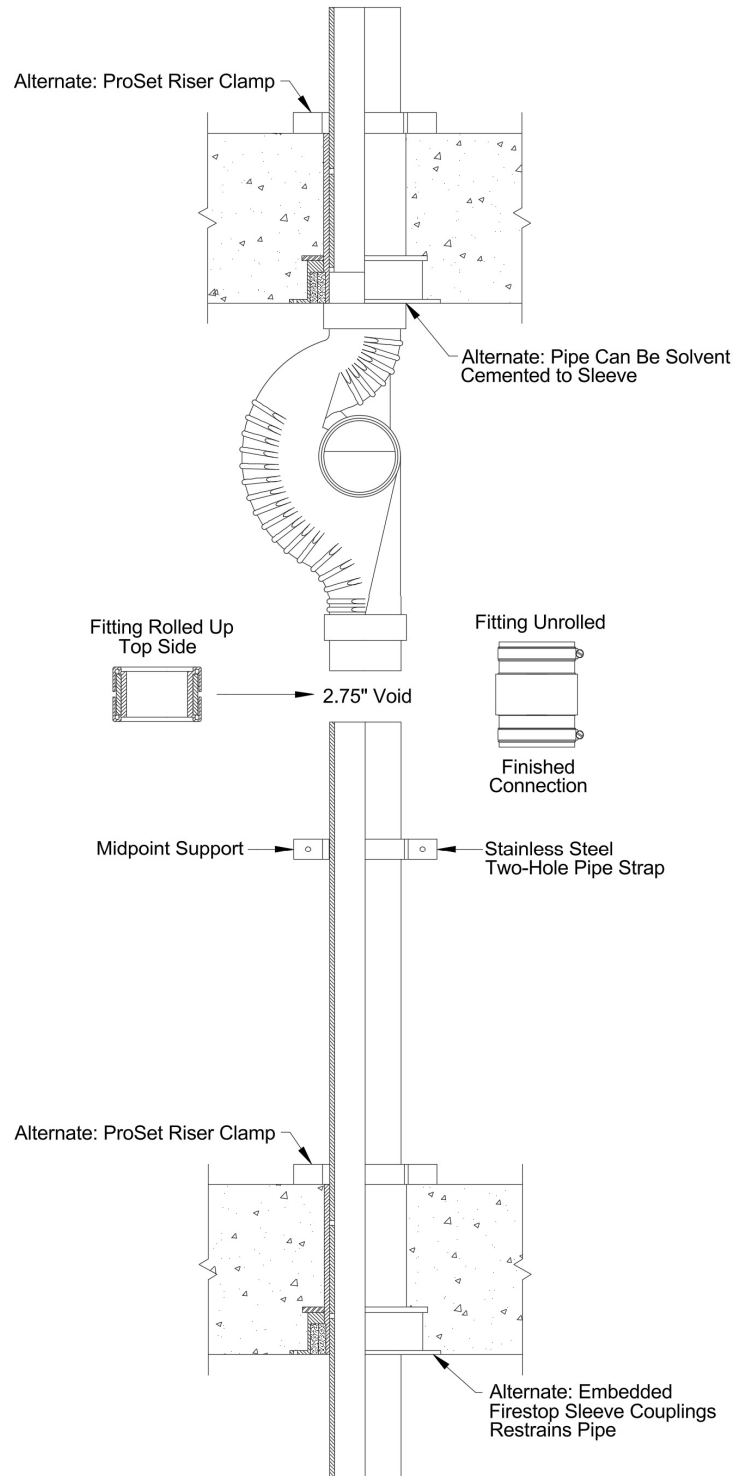

BaseVent Fitting Rule 2.1

A ProVent Base Fitting must be installed at the base of each vertical stack before it enters the horizontal building drain. If the vertical distance to the closest ProVent Stack Fitting exceeds twenty feet (20'-0") an inline offset must be installed within five feet (5'-0") above the ProVent Base Fitting. The building drain size is calculated by using Chart 4 in accordance with the fixture unit values (D.F.U.) for all fixtures discharging into it as shown in Chart 1.

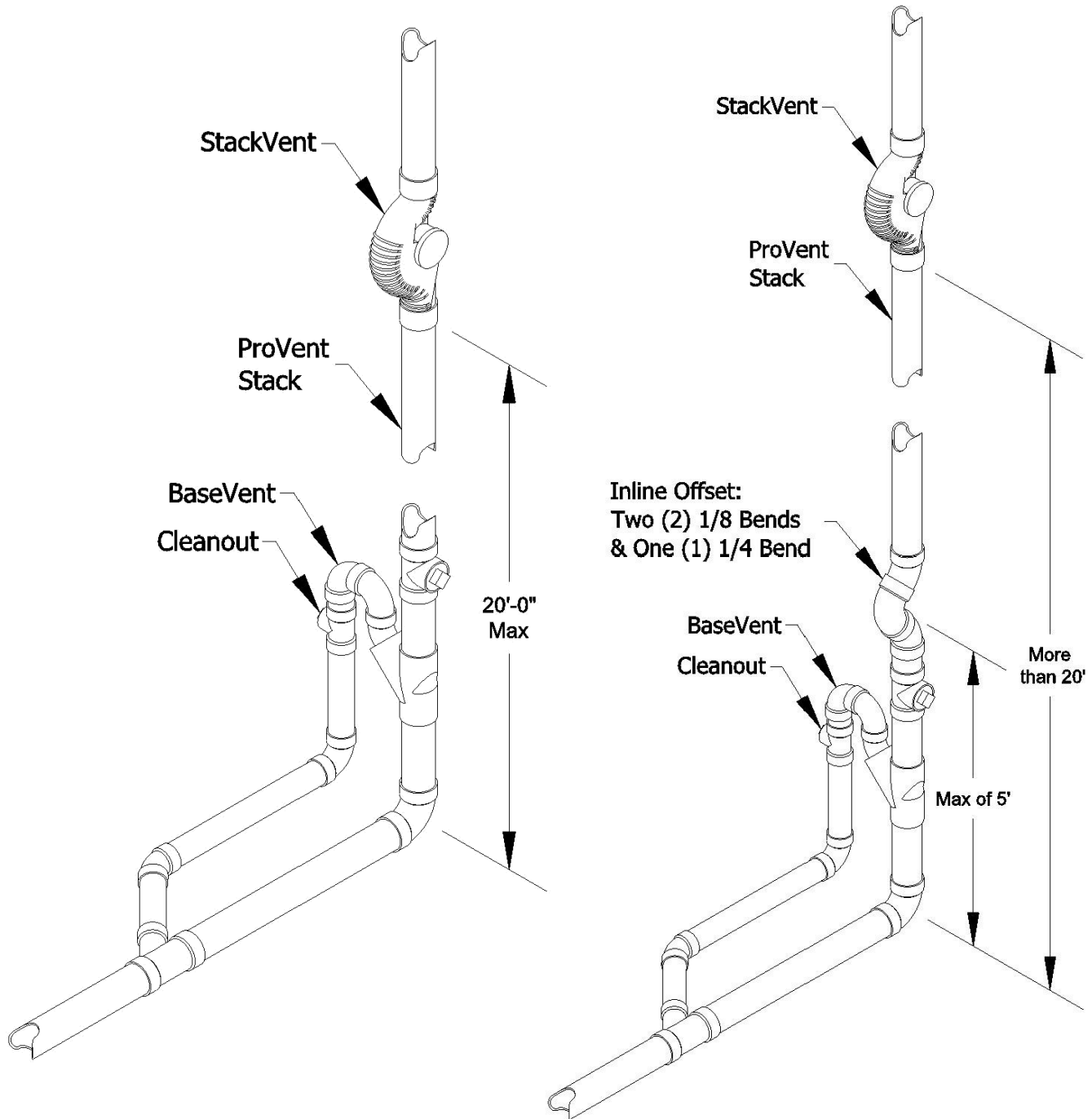

Drawing 2.1



BaseVent Fitting Rule 2.2

The ProVent Base Fitting has a pressure relief vent opening that extends up then makes a 180 degree turn downward using pipe and fittings that connect to the horizontal building drain at a point no less than 10 pipe diameters downstream from the center line of the vertical stack to the centerline of the branch wye. The pressure relief vent line may run parallel to the horizontal drain and must connect at a 45° angle or greater above the centerline of the drain.

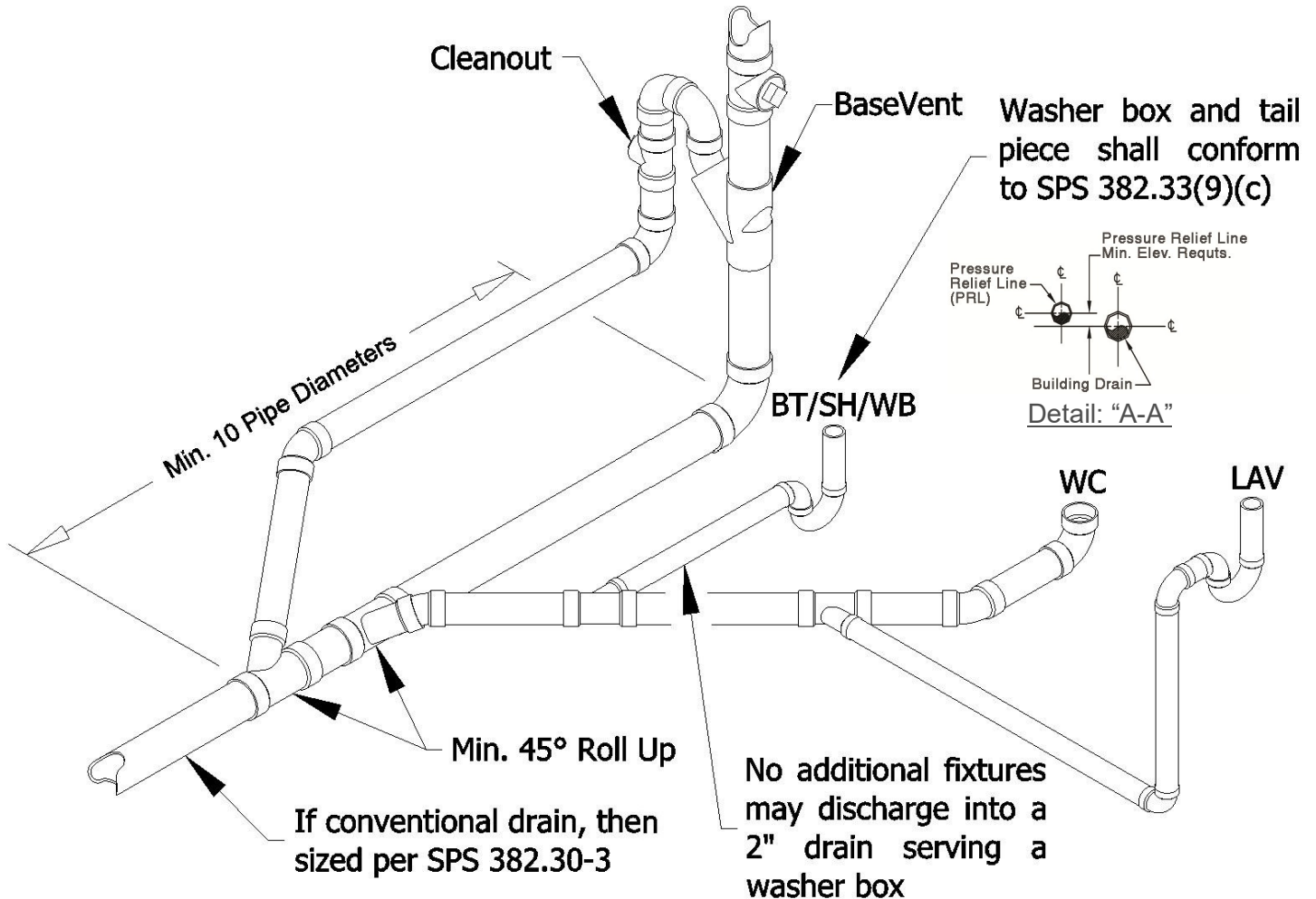

Drawing 2.2



BaseVent Fitting Rule 2.3

A ProVent Base Fitting must be used on any stack offsets within the stack of more than 60 degrees with the pressure relief vent connection running from the base fitting back into the vertical drop portion of the stack. A cleanout is required at the base of the stack. When there are no fixture openings taken off the horizontal building drain, a cleanout must also be added to the vertical PRL line.

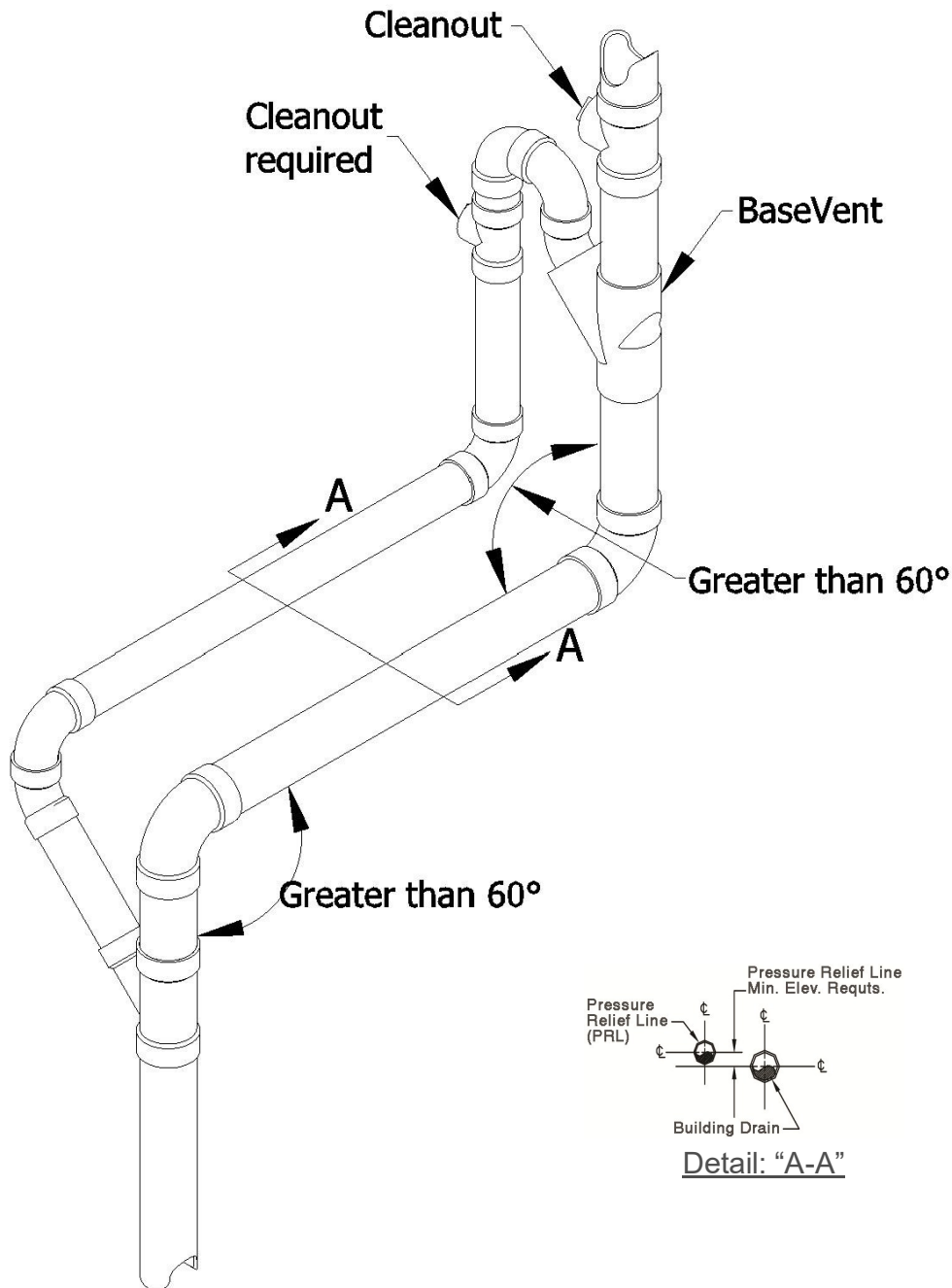

Drawing 2.3



BaseVent Fitting Rule 2.4

Soil and waste branches can be connected into the building drain between the stack and the relief vent when the connections are made above the center line of the building drain. Above centerline branch connections are not required when branches are made a minimum of 40 inches down from the centerline of the stack and upstream from the PRL. Branch loading should be in accordance with Chart 2.

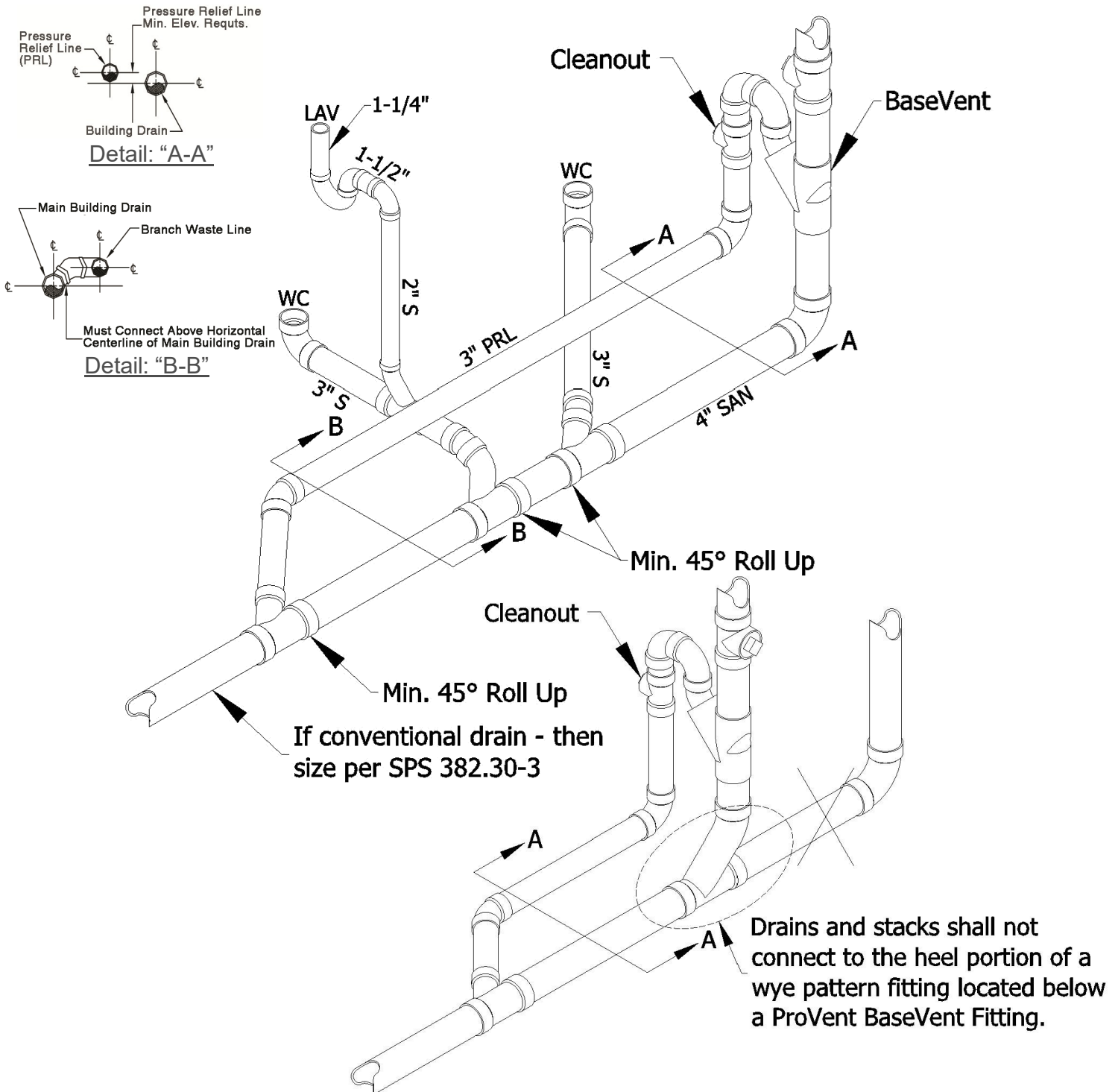

Drawing 2.4



BaseVent Fitting Rule 2.5

Waste branches at least (1) one pipe size smaller can be connected to the pressure relief horizontal vent line. No waste branch is allowed to connect to the 2" PRL. No connection should be made into the vertical portion of the PRL.

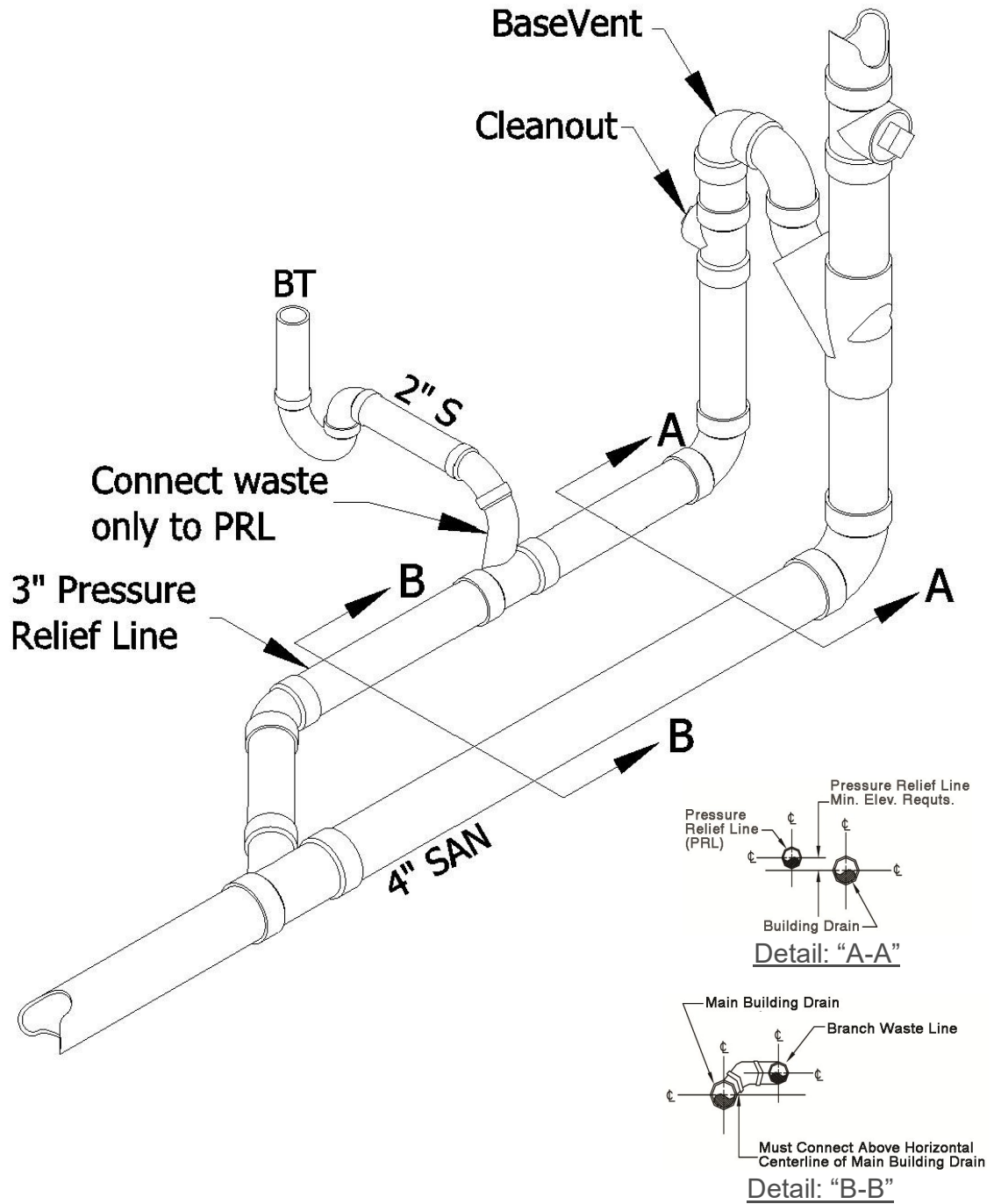

Drawing 2.5



BaseVent Fitting Rule 2.6

Soil or waste branches may connect directly into the vertical stack directly below the ProVent Base Fitting only when the connections are made using fittings such as a combination wye and 1/8 bend.

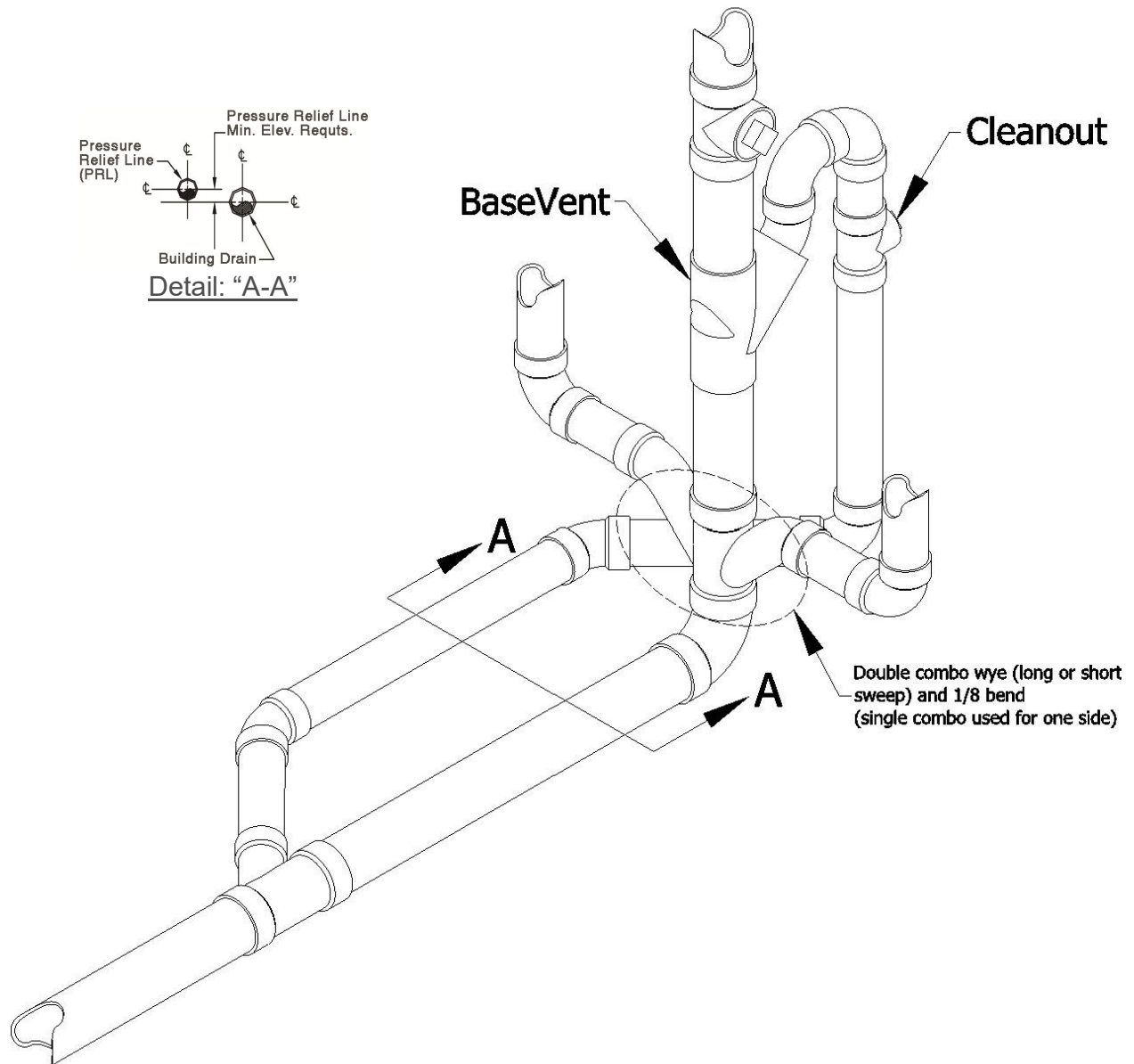

Drawing 2.6



BaseVent Fitting Rule 2.7

Soil and waste branches can connect downstream from the pressure relief vent to pick up remote conventional plumbing fixtures. Conventional plumbing vents can tie back into the ProVent vertical stack below the Stack Fitting using an upright wye and 1/8 bend. Vent sizing is based on the additional fixture units or the vents can be separately vented through the roof in accordance with locally accepted plumbing code venting methods and sizing.

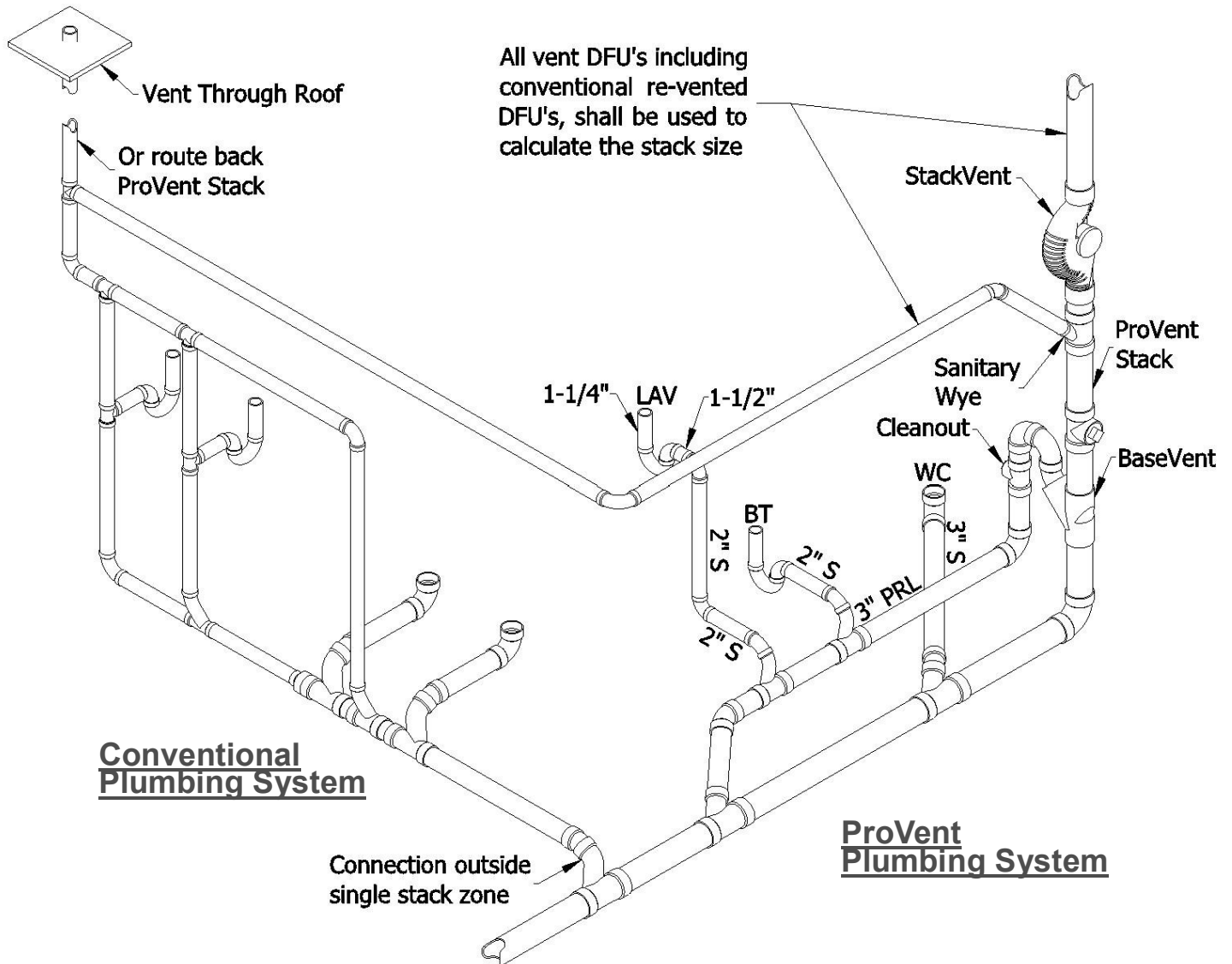

Drawing 2.7



Branch Opening Rule 3.1

All branch piping sizes and loads should be in accordance with Chart 2. Branch piping should have a minimum of 1/8" per foot pitch.

(See Chart 2)

Branch Opening Rule 3.2

Changes in direction on horizontal branches by 90° shall be made with two (2) forty five degree fittings or a long turn 90 degree fitting.

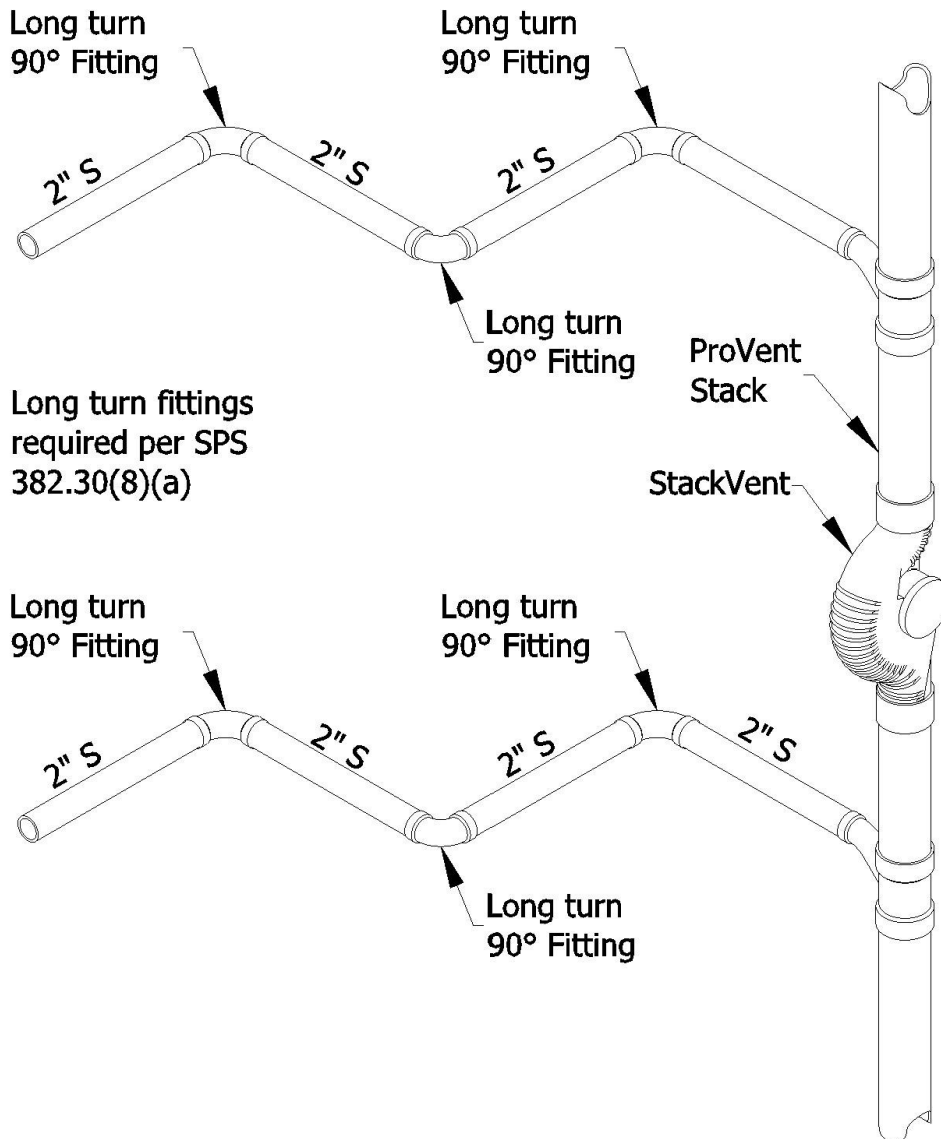

Drawing 3.2



Branch Opening Rule 3.3

If two (2) 3.5 gpf public water closets are connected to the same branch, the first connection can be 3" then increased to 4" at the second connection. This increase is not required for the 1.6 gpf low flush water closets. Check manufacturers installation instructions for pressure assisted type water closets or large flush valves that may require special fittings or spacing requirements for back to back installations.

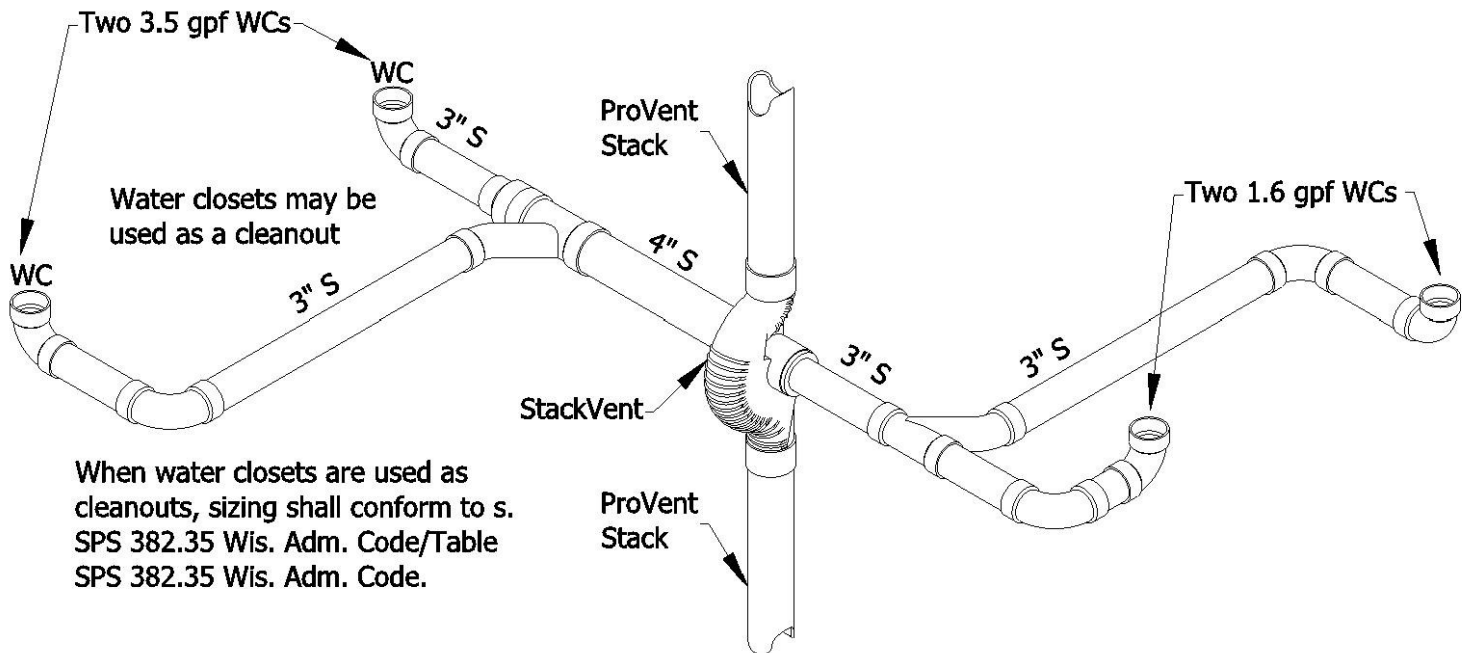

Drawing 3.3



Branch Opening Rule 3.4

4" Size branches shall not exceed a developed length of 27 feet. 3" Size branches shall not exceed a developed length of 15 feet. 2" Size branches shall not exceed a developed length of 15 feet. These lengths include all the horizontal pipe but the length of the vertical drop arms is not included (see Rule 3.5 for restrictions on vertical drops). Horizontal to horizontal branch connections should be made with wye combinations or heel outlet fittings.

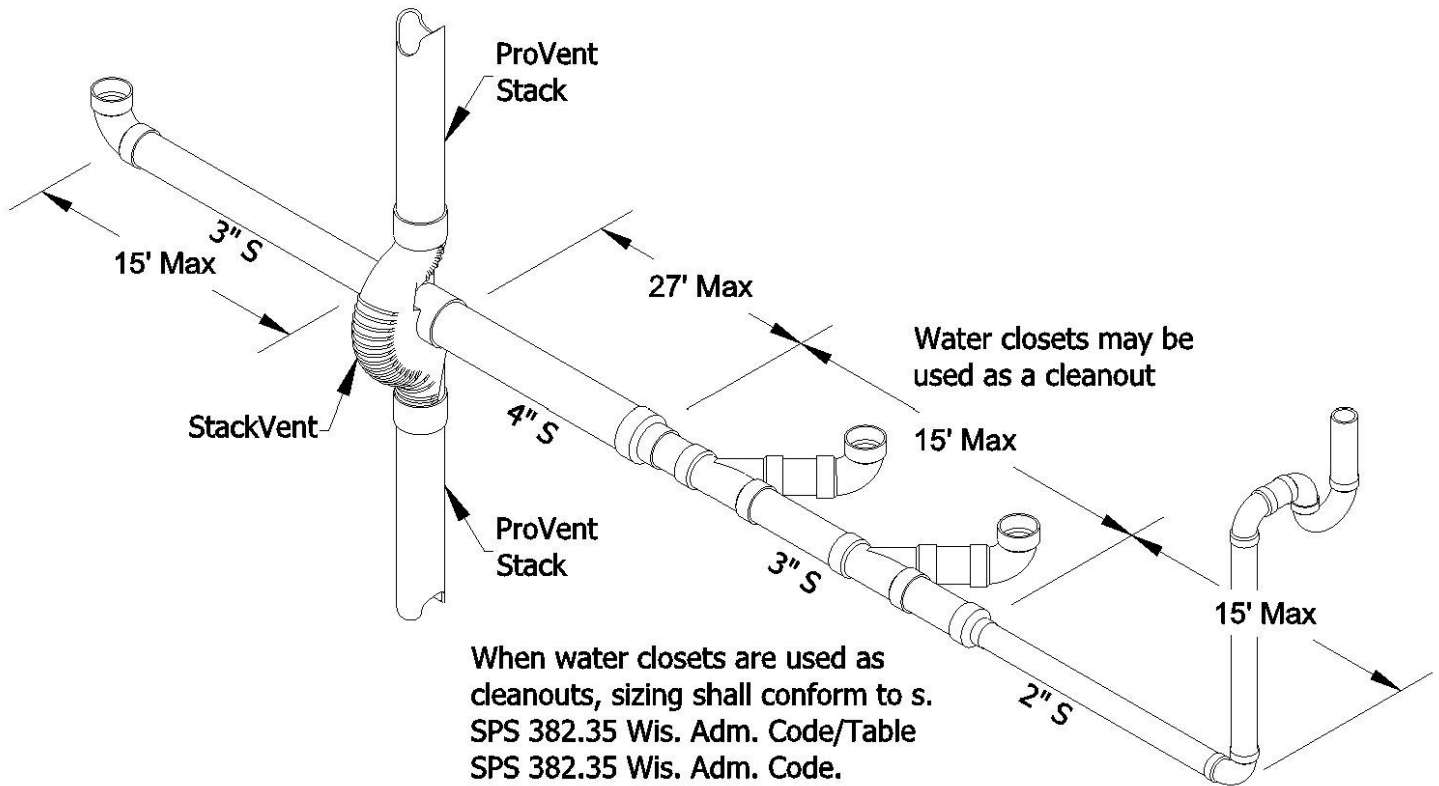

* A maximum distance of 27 ft. is allowed on a 4" soil branch. However, it is recommended that the use of 3" pipe be maximized for 1.6 GPF toilet systems.

Drawing 3.4



Branch Opening Rule 3.5

Vertical branches should not exceed 40". A 45 degree offset can extend the drop pipe to 40" from the top 45 degree fitting to the fixture outlet. Branch piping with a vertical drop into a horizontal waste exceeds 10 feet both must increase one (1) pipe size.

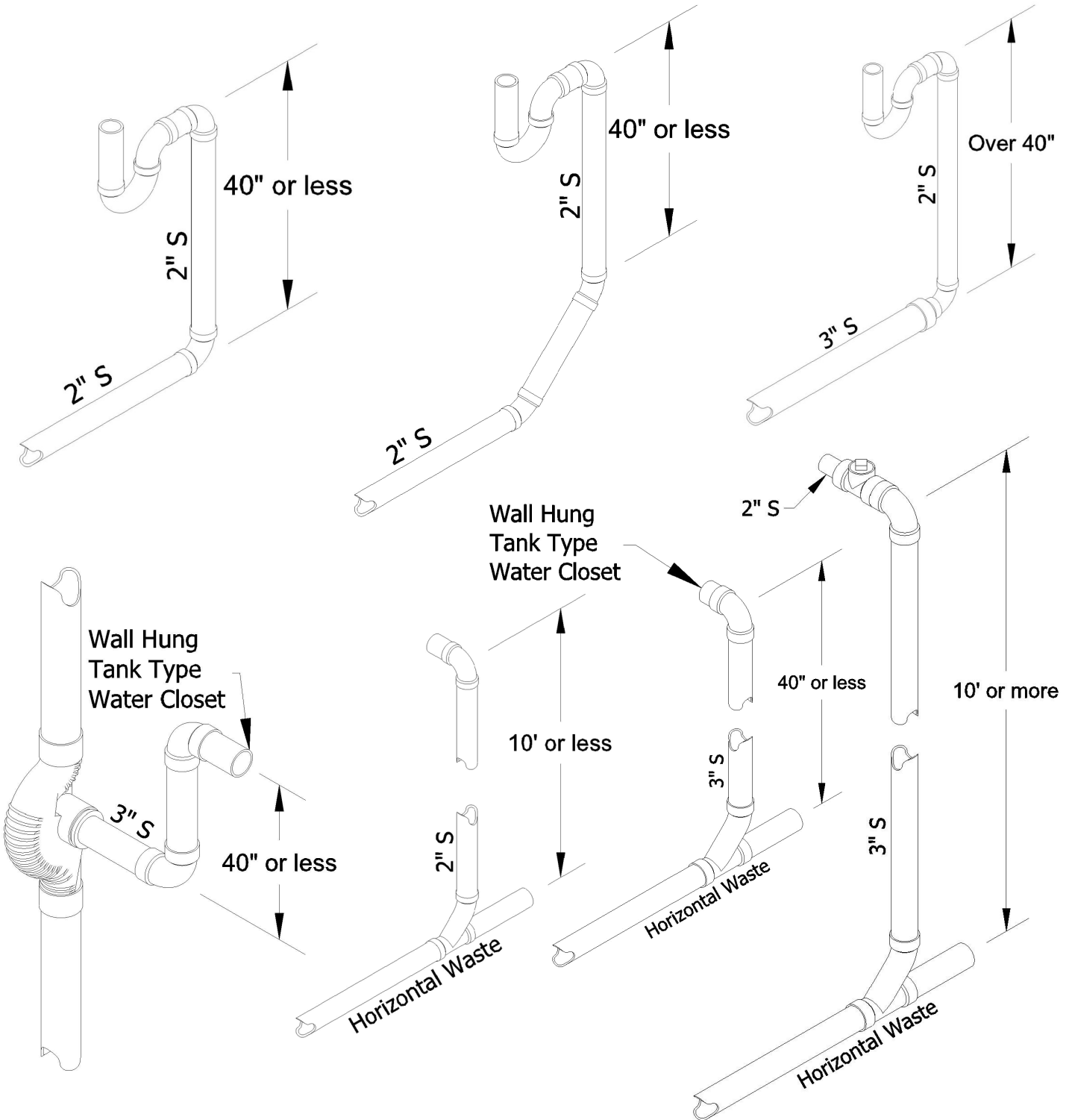

Wall outlet water closets using prefabricated carriers shall be vented in accordance with the carrier manufacturers published instructions.

Drawing 3.5



Branch Opening Rule 3.6

1-1/4" size fixture traps can be connected back to back into one 2" vertical drop. A maximum of (2) 1-1/2" size fixture traps serving the same fixture may be served by (1) 2" vertical drop. Larger traps can use a single vertical drop by increasing the drop one (1) pipe size. Horizontal waste branches without vertical drops are sized per chart 2.
 Special Note: ProVent systems recommends and designs washing machine connections to serve washing machines which require the use of no sudsing high efficiency detergents.

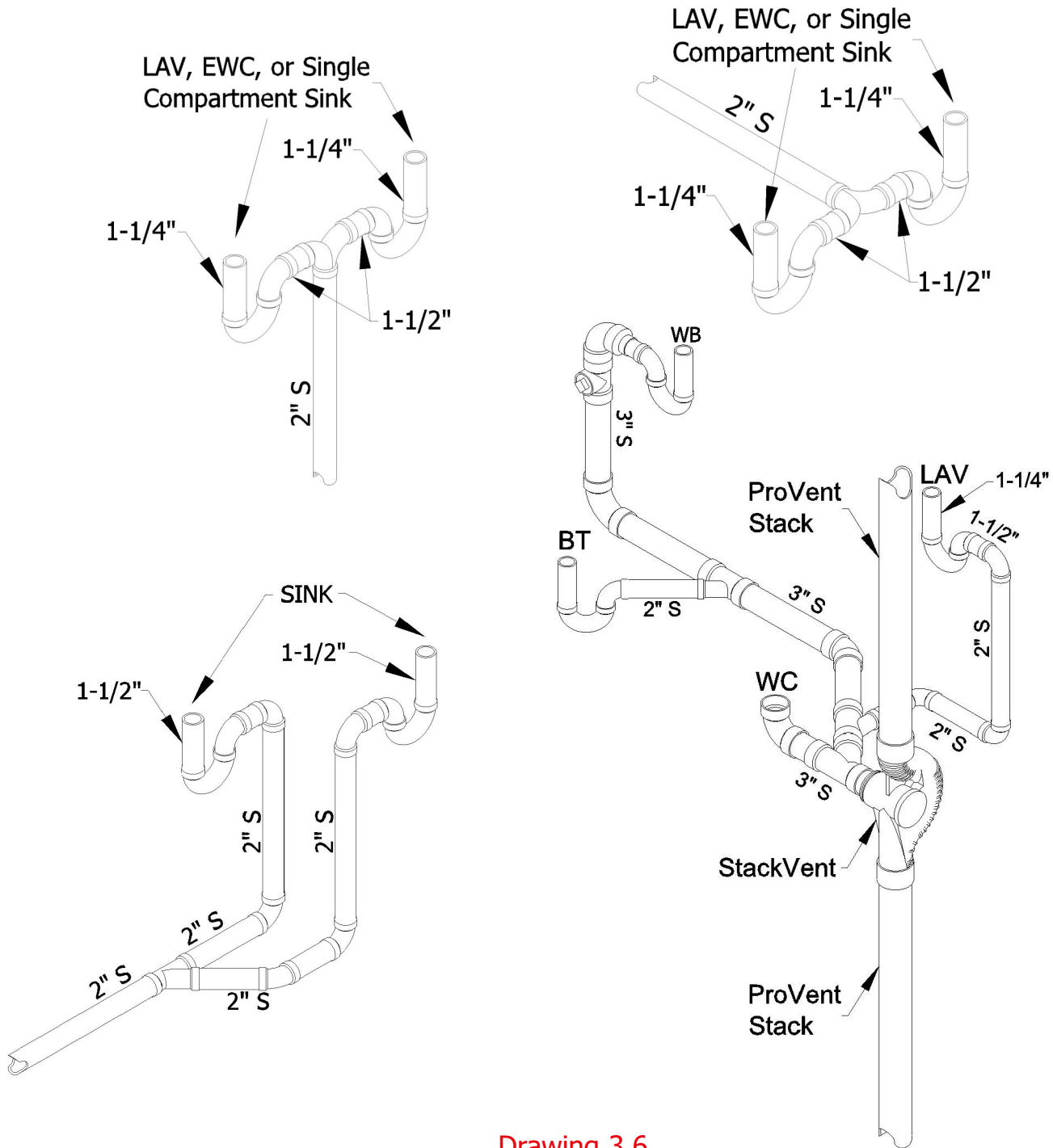

Drawing 3.6



Branch Opening Rule 3.7

An alternate to increase developed lengths can be done by using a revent line or by telescoping smaller to larger pipe sizes or by using an Air Admittance Valve where applicable and permitted. The revent line shall be routed vertically and horizontally and tie in above the flood rim level using a wye branch looking up.

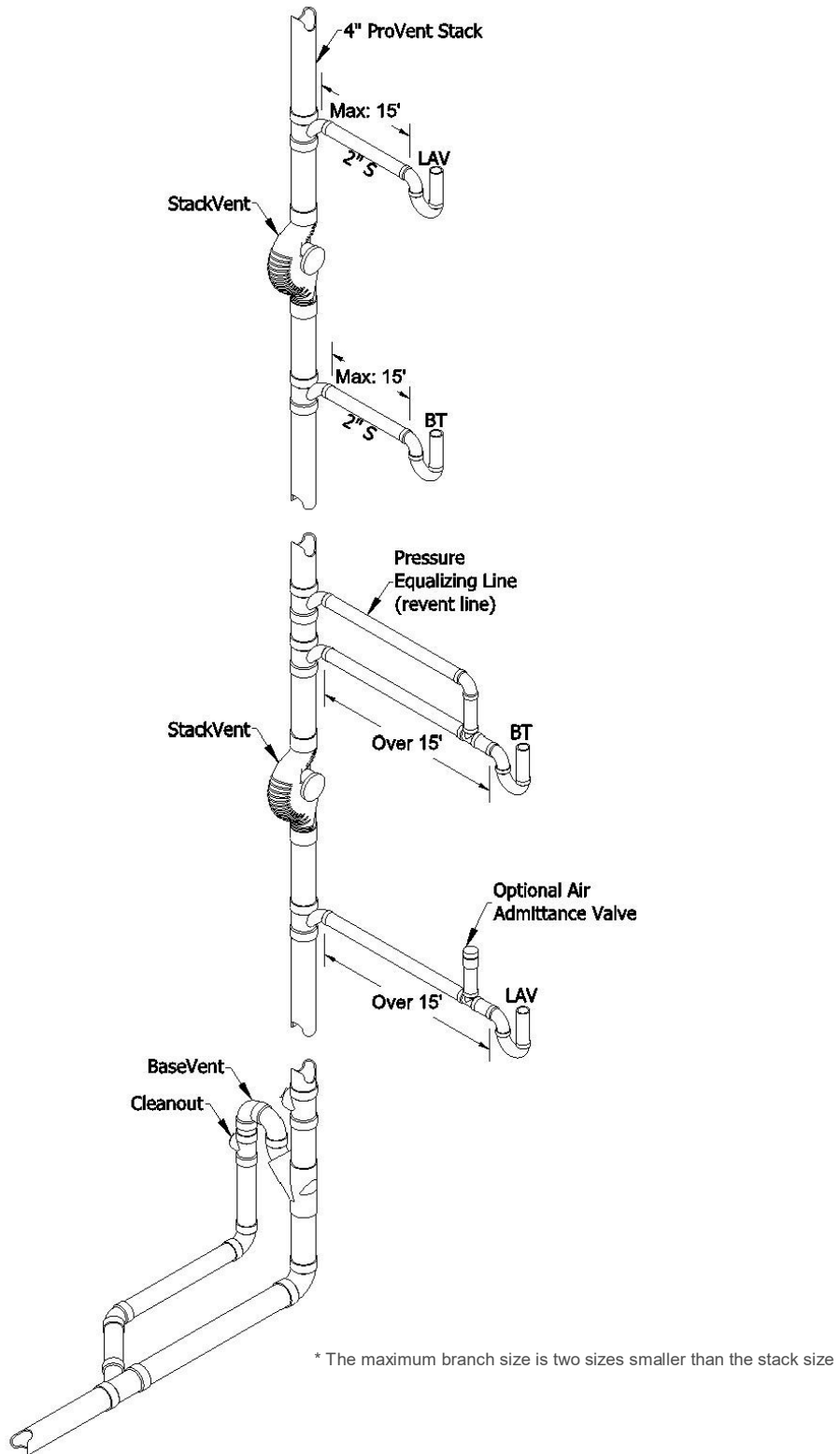

Drawing 3.7



Other Examples of ProVent Fixture Branches

Lavatories: Vertical Branch

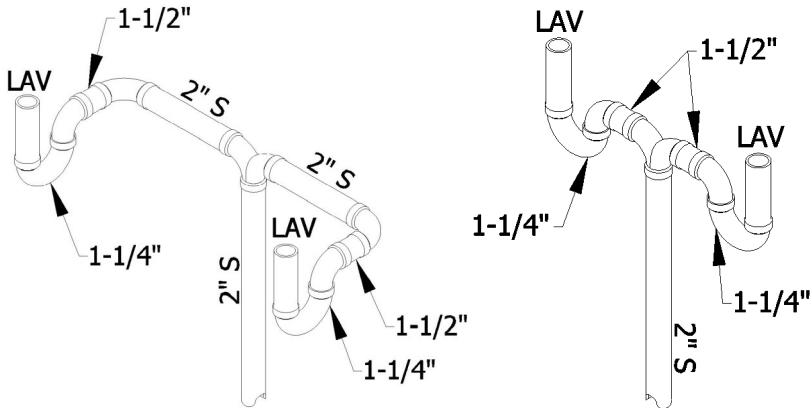

Drawing 31a

Lavatories: Horizontal Branch

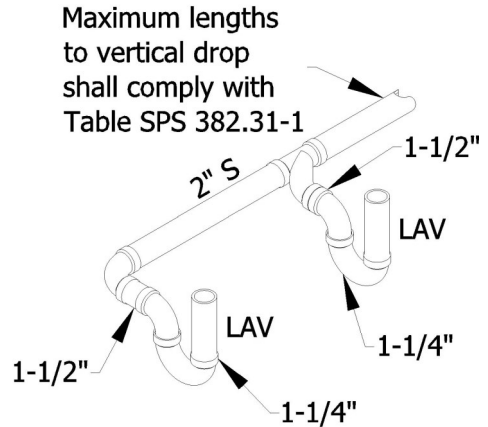

Drawing 31b

Sinks: Vertical Branch

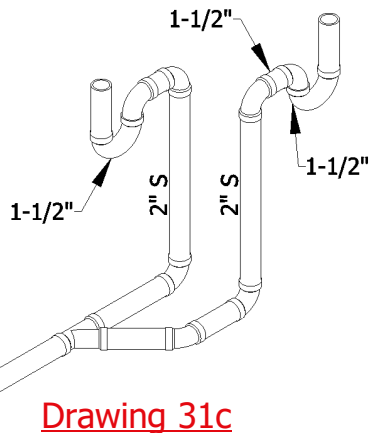

Drawing 31c

Sinks: Horizontal Branch

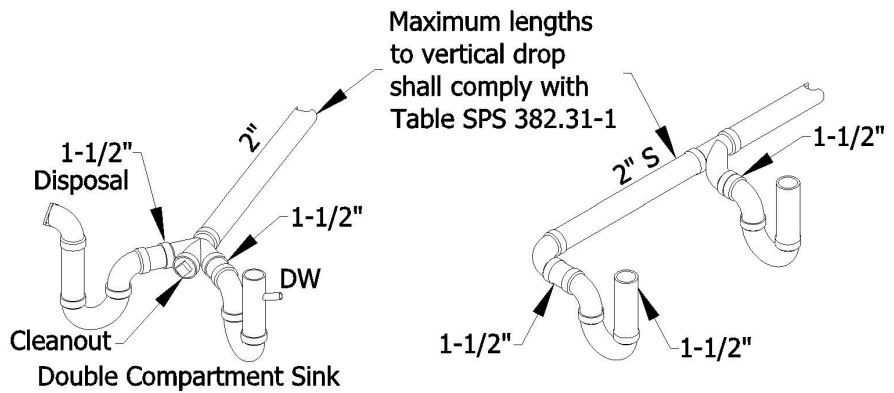

Drawing 31d

Washing Machines: Vertical Branch
(Using HE Detergents)

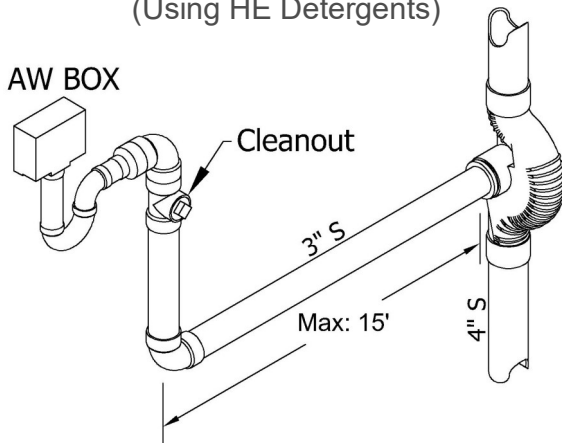

Drawing 31e

Washing Machines: Horizontal Branch
(Using HE Detergents)

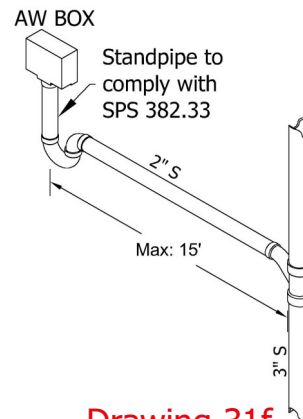

Drawing 31f



Example: Side by Side Layouts

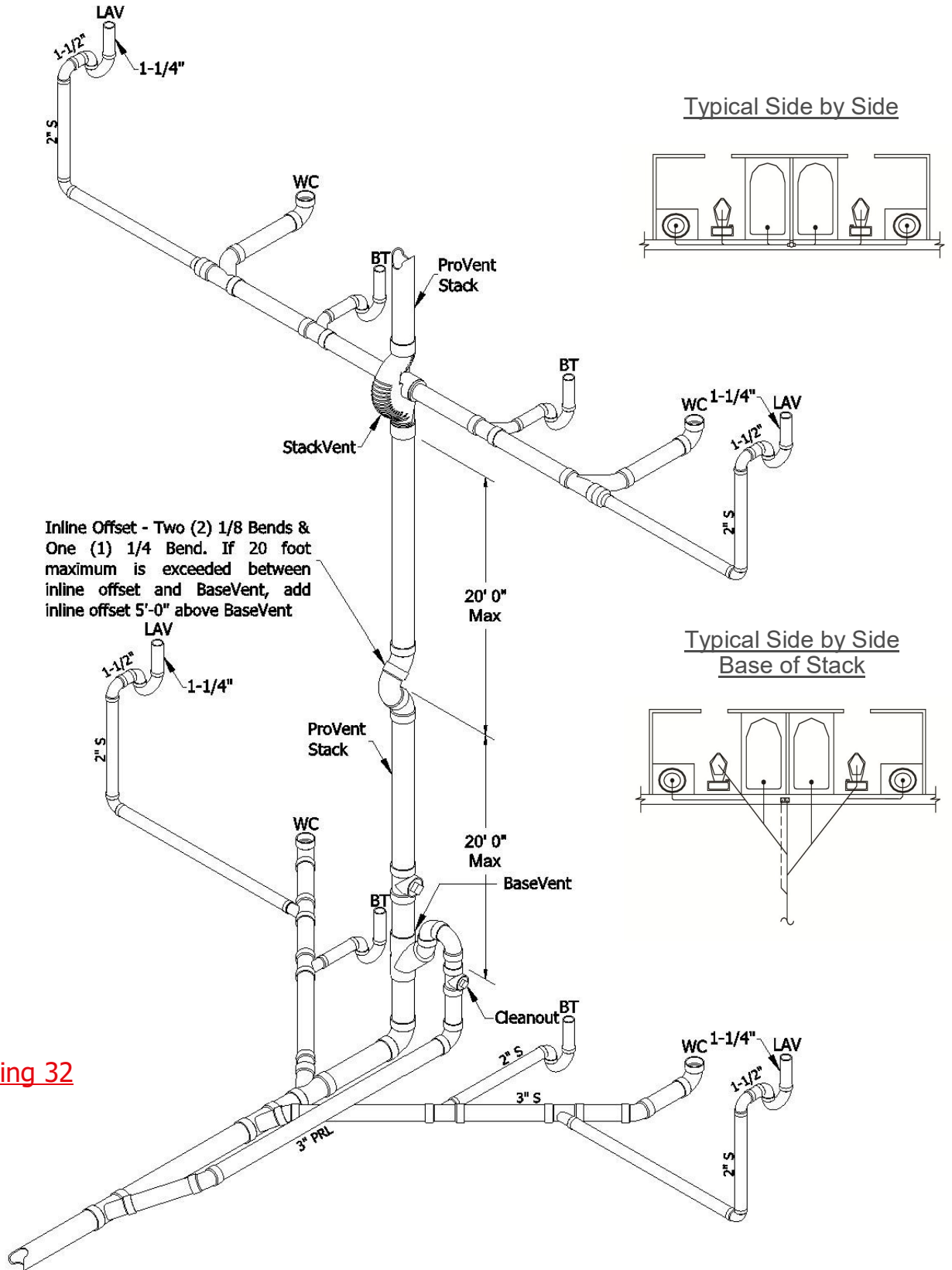

Drawing 32



Example: Single Unit Layouts

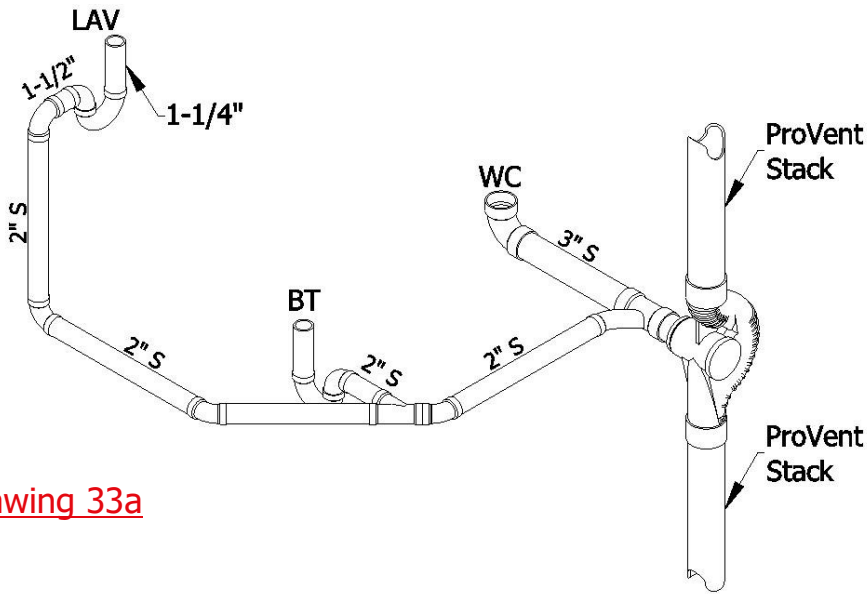

Drawing 33a

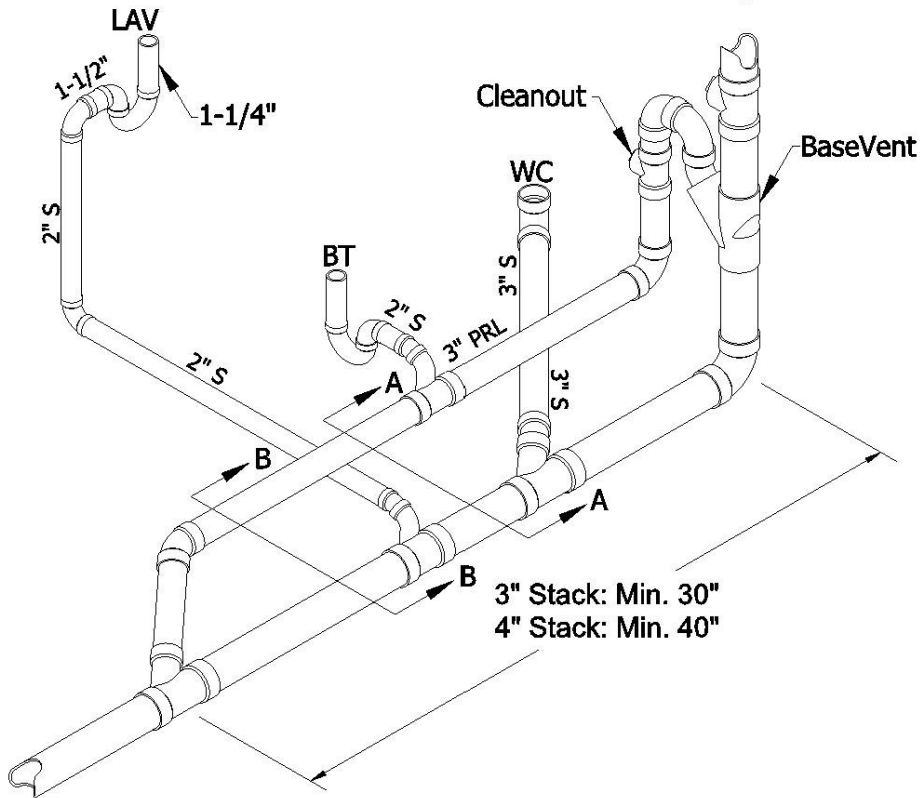
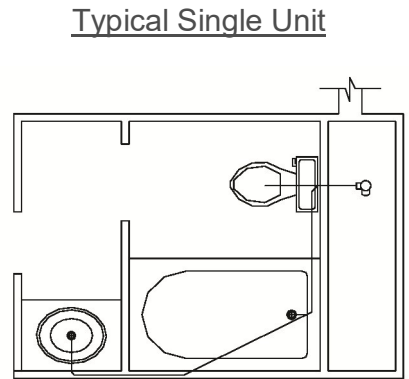

Drawing 33b

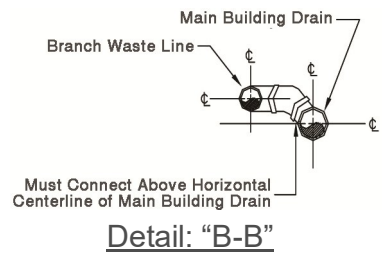
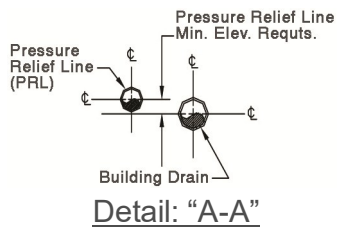
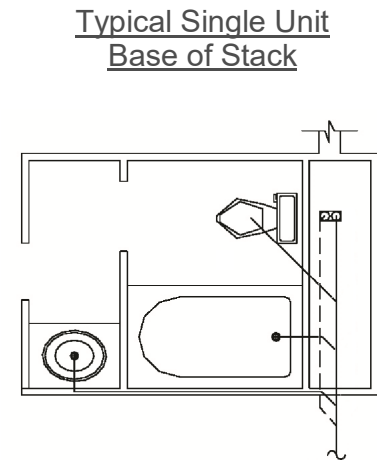

Example 1: Back to Back Layouts

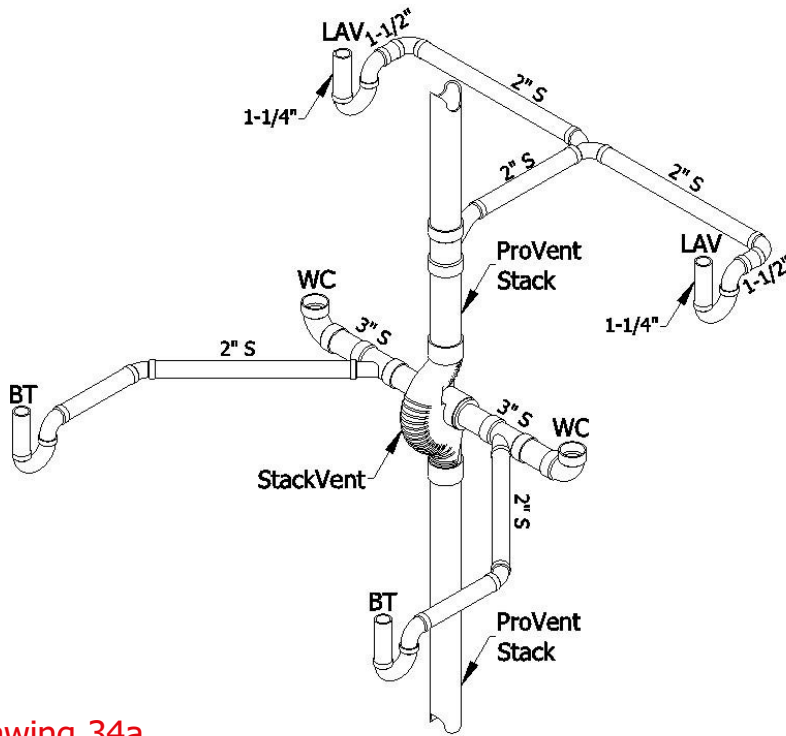

Drawing 34a

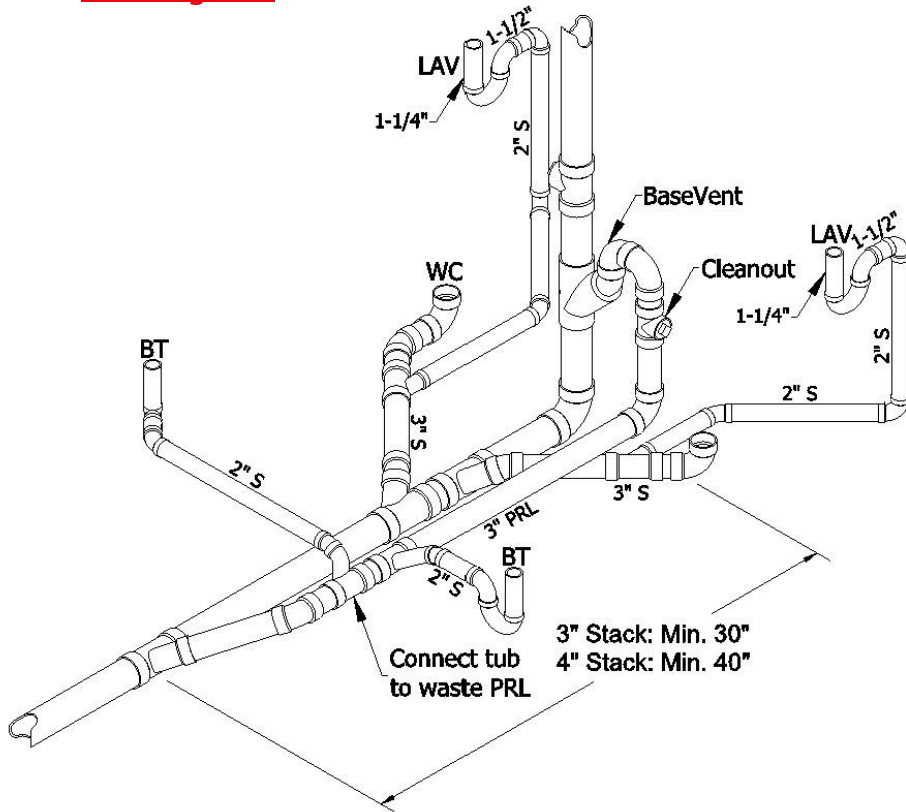
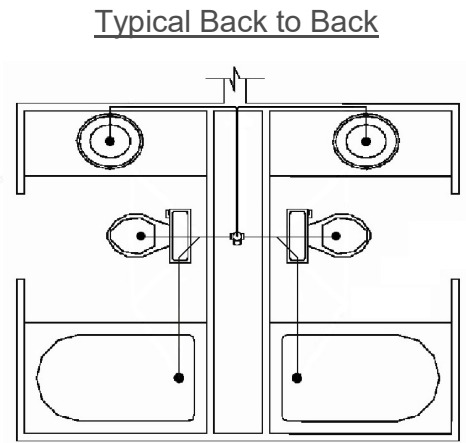

Drawing 34b

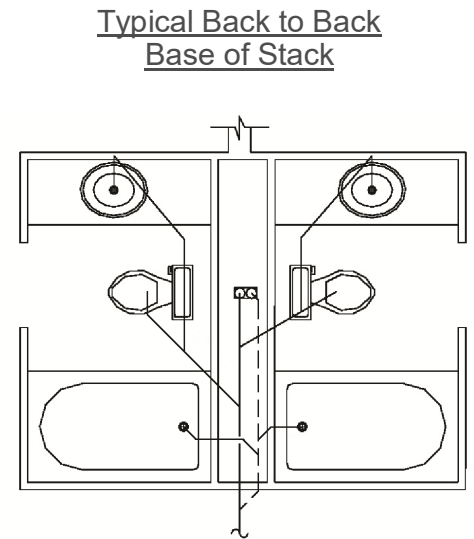

Example 2: Back to Back Layouts (Alternative Layout for Upper Floors)

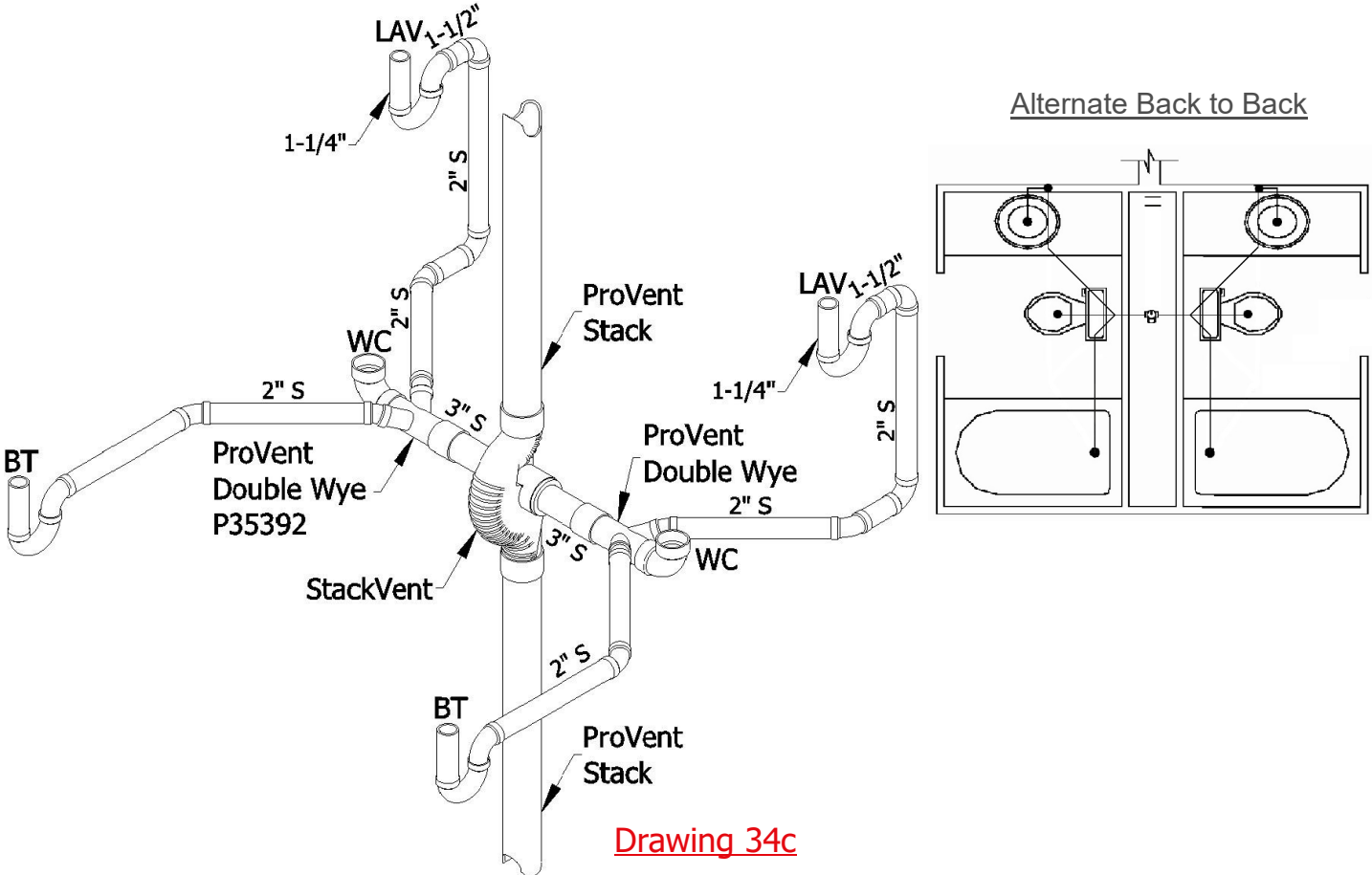

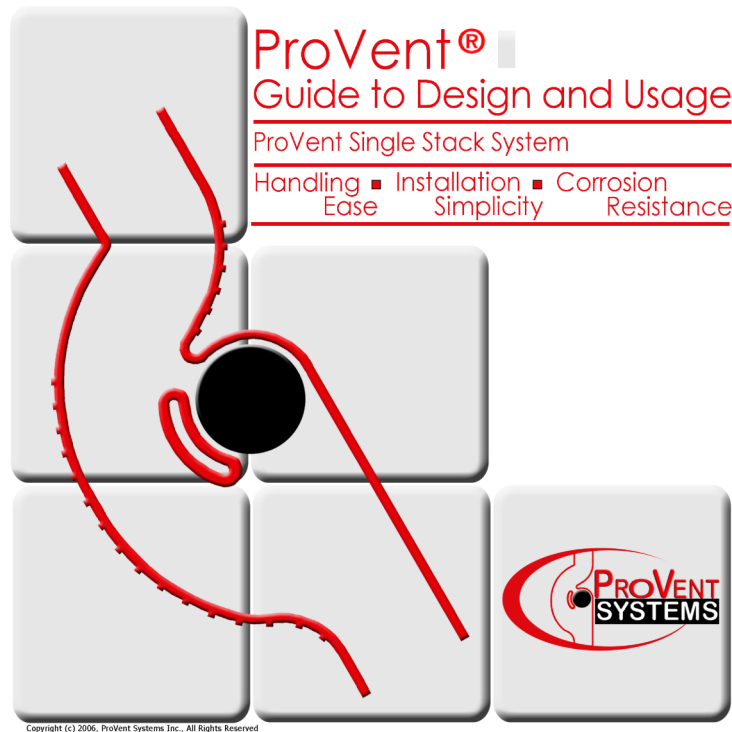

IMPORTANT NOTICE

This manual shows the basic plumbing rules that have been used for over 40 years for both the copper and cast iron Sovent systems. The same rules apply for this PVC plastic ProVent System that includes both the ProVent Stack and Base fittings.

ProVent Systems may include conventional plumbing that must be installed in accordance with local plumbing codes. The vents from conventional plumbing may be tied into the ProVent stack as indicated within this manual.

ProVent Systems can assist in job design and inspections under certain understood conditions with the contractor or plumbing engineer. Job quotations may or may not include these services where required. Contact us for further information.

All additional piping, fittings, pipe supports, firestopping and other items that are supplied by others, should be in strict accordance with good piping practices and all applicable codes having jurisdiction.

When the rules used in this manual are adhered to without any deviations the system is known to function properly. However, any unknown deviation may reduce the integrity of this system. Therefore, the user must assume all responsibility for the integrity and performance of the completed DWV plumbing system and for adherence to all the rules included in this manual.

ProVent Systems cannot assume responsibility for the performance of the complete DWV system other than for the performance of the individual components supplied by ProVent Systems, as stated in the "Limited Parts Warranty", below.

LIMITED PARTS WARRANTY

Sellers products are carefully inspected for manufacturing defects; however, it is not always possible to detect hidden defects. Said products are warranted only to the extent that seller will replace without charge, products proved to have manufacturing defects within 6 months of the date of delivery thereof and provided seller has been given an opportunity to inspect the product alleged to be defective and the installation or use thereof. NO WARRANTY IS INCLUDED AGAINST ANY EXPENSE FOR REMOVAL, REINSTALLATION OR OTHER CONSEQUENTIAL DAMAGES ARISING FROM ANY DEFECT. THE WARRANTIES SET OUT ABOVE ARE THE ONLY WARRANTIES MADE BY SELLER AND ARE EXPRESSLY IN LIEU OF ALL OTHER WARRANTIES, EXPRESSED OR IMPLIED, INCLUDING THE WARRANTIES OR MERCHANTABILITY AND FITNESS FOR A PARTICULAR PROPOSE.

ProVent Systems Inc. ■ 1355 Capital Circle ■ Lawrenceville ■ Georgia ■ 30043-5866
770-339-1782 ■ 800-262-5355 ■ Fax: 770-339-1784
■ www.ProVentSystems.com ■