



CSI: DIVISION: 22 00 00—PLUMBING
Section: 22 13 16—Sanitary Waste and Vent Piping

Product certification system:

The ICC-ES product certification system includes testing samples taken from the market or supplier's stock, or a combination of both, to verify compliance with applicable codes and standards. The system also involves factory inspections, and assessment and surveillance of the supplier's quality system.

Product: ProSet Trap Guard® - Trap Primer Alternate in sizes 2 and 3 inches for use in shower floors, concrete floors and ceramic tile floors.

Listee: ProVent a division of IPS Corporation
500 Distribution Parkway
Collierville, Tennessee 38017
www.trapguard.com

Additional Listee:

Tyler Pipe
Wade Division
11910 CR 492
Tyler, Texas 75706

Compliance with the following codes:

2024, 2021, 2018, 2015, 2012, 2009 and 2006 *International Plumbing Code®* (IPC)
2024, 2021, 2018, 2015, 2012, 2009 and 2006 *International Residential Code®* (IRC)
2024, 2021, 2018, 2015, 2012 and 2009 *Uniform Plumbing Code®* (UPC)*
2022 *Uniform Illustrated Plumbing Code – India™* (UIPC-I)*
2020, 2015 and 2010 *National Plumbing Code of Canada***

**Uniform Plumbing Codes®* are copyrighted publications of the International Association of Plumbing and Mechanical Officials
***National Plumbing Code of Canada* is a copyrighted publication of National Research Council Canada

Compliance with the following standards:

ASSE 1072-2020 - (Table 2 sections applicable to SF-Shower floor, CF- Concrete Floor and CT Ceramic Tile Floor) Performance Requirements for Barrier Type Floor Drain Trap Seal Protection Devices, American Society of Sanitary Engineering.
ASME A112.6.3/CSA B79.3-2022 Floor Drain
ICC-ES LC1015 (October 2010) - PMG Listing Criteria for Elastomeric, Normally Closed, Floor Drain Evaporation Resistant Sealing System.

Identification:

The product and/or package insert must bear the manufacturer's name, the model number and the ICC-ES PMG listing mark.

Installation:

ProSet Trap Guard® - Trap Primer Alternate and Tyler Pipe models are to be installed on floor drains conforming to ASME A112.6.3/CSA B79.3, General Purpose Drains, in accordance with the manufacturer's instructions, this listing and the applicable code. ProSet Trap Guard® and Tyler Pipe models must be installed above the trap seal of the floor drain.

Models:

See Table 1 – Trap Guard Models

Component Model #	Floor Drain Size		Flow Rates	
	Inches	mm DN	GPM	L/M
TG22	2	50	12	45.4
TG33	3	80	34	128.7

See Table 2 – Tyler Pipe, Wade Division Models

Conditions of listing:

1. ProSet Trap Guard® - Trap Primer Alternate devices and the Tyler Pipe models, recognized in this listing, is intended to serve as alternates to the code-required trap primer in floor drains conforming to ASME/ANSI A112.6.3/CSA B79.3, and must serve a functioning trap.
2. ProSet Trap Guard® - Trap Primer Alternate devices and Tyler Pipe models are not recognized for use in wood floors (subject to wax) or floors subject to grease-laden waste.
3. The plumbing systems must be installed in accordance with the applicable code in North America or with the UPC-I when installed in India.
4. The floor drain must be accessible and installed above the trap seal of the floor drain.
5. ProSet Trap Guard® - Trap Primer Alternates and Tyler Pipe models are under a quality control program with yearly inspections by ICC-ES.

TABLE 1—TRAP GUARD MODELS

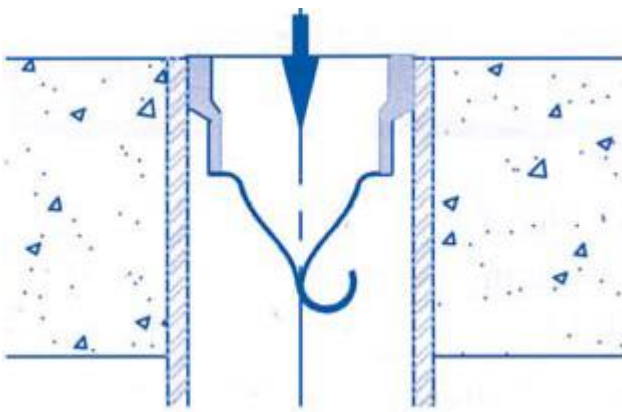
Retrofit Trap Guard Models		
	Model Number and Component	ProSet Trap Guard®- Description / Application
	SG22IP TG22	2" Suds Guard fits inside 2" C.I. pipe
	SG22P TG22	2" Suds Guard fits inside 2" PVC pipe
	TG22P TG22	2" TG fits inside 2" PVC pipe
	TG22IP TG22	2" TG fits inside 2" C.I. pipe
	TG22G TG22	2" TG fits through a 2" gasket to inside pipe
	TG22SC TG22	2" TG fits into 842-3 Sioux Chief tailpiece
	TG33IP TG33	3" TG fits inside 3" PVC or C.I. pipe
	TG33G TG33	3" TG fits through a 3" gasket to inside pipe

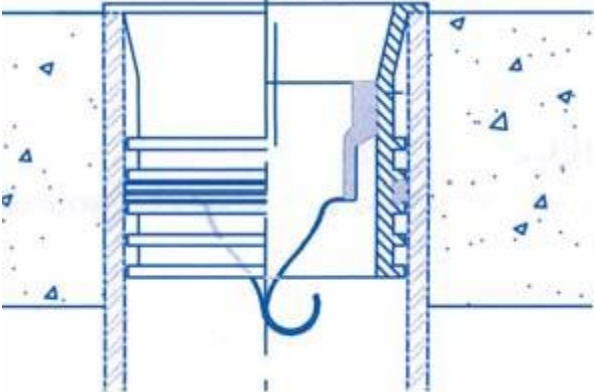
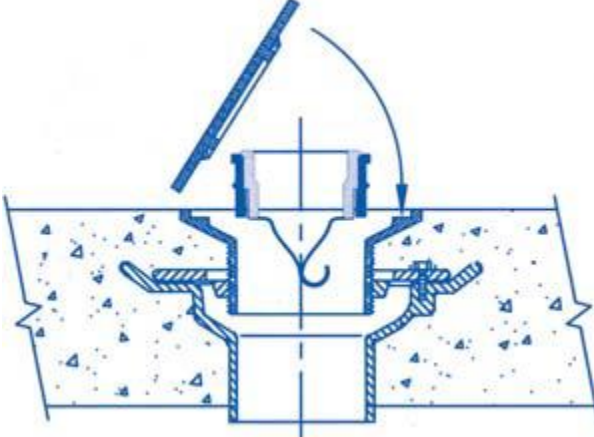
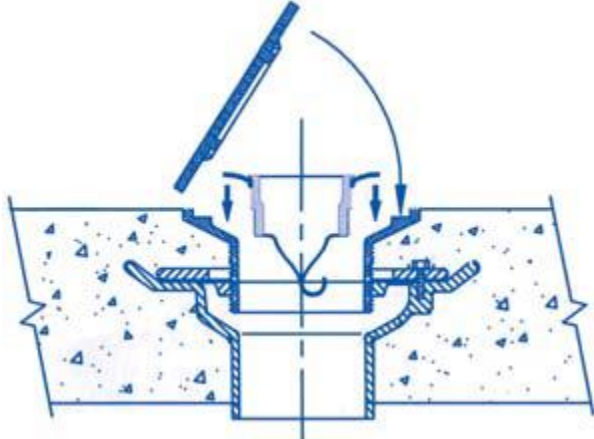
	<p>TG33SC TG33</p>	<p>3" TG fits into 842-3 Sioux Chief tailpiece</p>
	<p>TG34G TG33</p>	<p>3" TG fits through a 4" gasket to inside pipe</p>
	<p>TG34IP TG33</p>	<p>3" TG fits inside 4" PVC or C.I. pipe</p>
	<p>Model Number and Component</p>	<p>ProSet Trap Guard®- Description / Application</p>
	<p>TG3H TG33</p>	<p>3" TG fits inside Smith 2000 and Josam 3000</p>
	<p>TG34HM TG33</p>	<p>3" TG fits inside Mifab tailpiece</p>
	<p>TG34HW TG33</p>	<p>3" TG fits inside Watts tailpiece</p>
	<p>TG34SC TG33</p>	<p>3" TG fits into 842-4 Sioux Chief tailpiece</p>
	<p>Model Number and Component</p>	<p>ProSet Trap Guard®- Description / Application</p>
	<p>TG33Zurn TG33</p>	<p>3" TG fits inside Z415 tailpiece</p>
	<p>TG33Wade TG33</p>	<p>3" TG fits inside Wade tailpiece</p>
	<p>TG34TP TG33</p>	<p>3" TG fits inside 4" strainer tailpiece</p>

UNDERGROUND HUB DRAINS

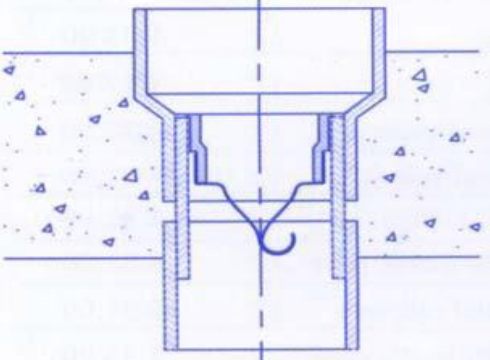
	<p>Model Number and Component</p>	<p>ProSet Trap Guard®- Description / Application</p>
	<p>TG23HD TG22</p>	<p>2" X 3" TG Underground Hub Drain</p>
	<p>TG23HD-CI TG22</p>	<p>For Cast Iron connections, add CI to part no.</p>

UNDERGROUND FLOOR DRAINS

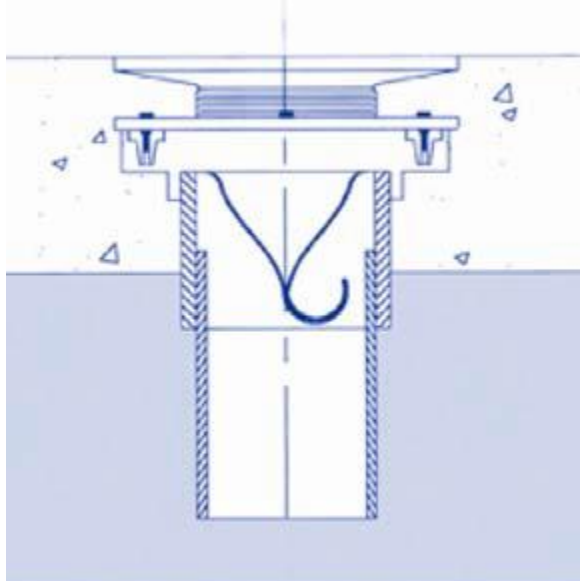
 <div style="border: 1px solid black; padding: 5px; margin-top: 10px; width: fit-content;"> <p>Connect to plastic pipe in ground floor slab</p> </div>	<p>Model Number and Component</p>	<p>ProSet Trap Guard®- Description / Application</p>
	<p>T25630-F-P TG22</p>	<p>2" Adj. NB ED w/ PVC plastic hub joint</p>
	<p>T35630-F-P TG33</p>	<p>3" Adj. NB ED w/ PVC plastic hub joint</p>
	<p>T35630-F-P- FU¹ TG33</p>	<p>Add FU for 2³/₈" X 3¹/₂" funnel top drain</p>

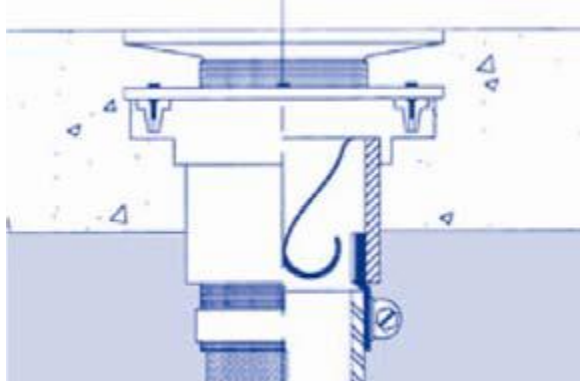
	<p>Model Number and Component</p>	<p>ProSet Trap Guard®- Description / Application</p>
	<p>T25630-F-CI TG22</p>	<p>2" Adj. NB ED w/ mechanical hub joint for C.I.</p>

	<p>T35630-F-CI TG33</p>	<p>3" Adj. NB ED w/ mechanical hub joint for C.I.</p>
	<p>T35630-F-CI-FU¹ TG33</p>	<p>Add FU for 2³/₈" X 3¹/₂" funnel top drain</p>

ABOVEGROUND FLOOR DRAINS

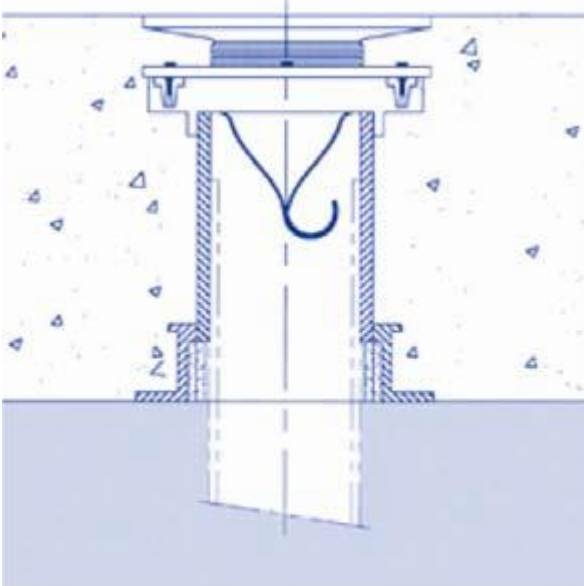
 <p style="border: 1px solid black; padding: 5px; margin-top: 10px;">Connect to plastic pipe above ground floor slab</p>	<p>Model Number and Component</p>	<p>ProSet Trap Guard®- Description / Application</p>
	<p>T2563H-F-SSW TG22</p>	<p>2" Adj. NB ED for plastic pipe above ground floor</p>
	<p>T3563H-F-SSW</p>	<p>3" Adj. NB ED for plastic pipe above ground floor</p>
	<p>T3563H-F-SSW-FU¹</p>	<p>Add FU for 2³/₈" X 3¹/₂" funnel top drain</p>

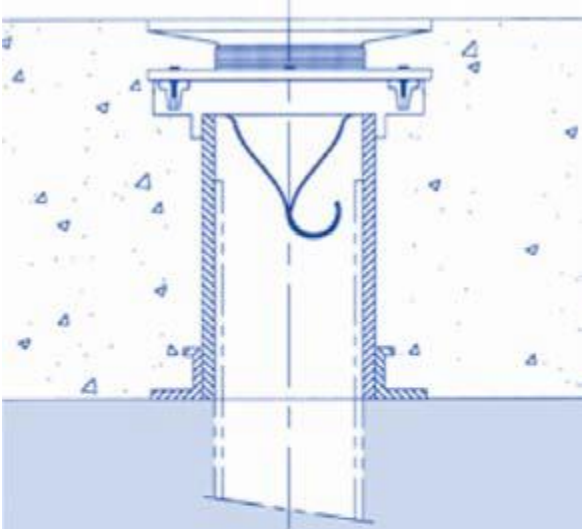
 <p style="border: 1px solid black; padding: 5px; margin-top: 10px;">Connect to cast iron pipe</p>	<p>Model Number and Component</p>	<p>ProSet Trap Guard®- Description / Application</p>
	<p>T2563H-F-CI TG22</p>	<p>2" Adj. NB ED for C.I. pipe above ground floor</p>
	<p>T3563H-F-CI TG33</p>	<p>3" Adj. NB ED for C.I. pipe above ground floor</p>

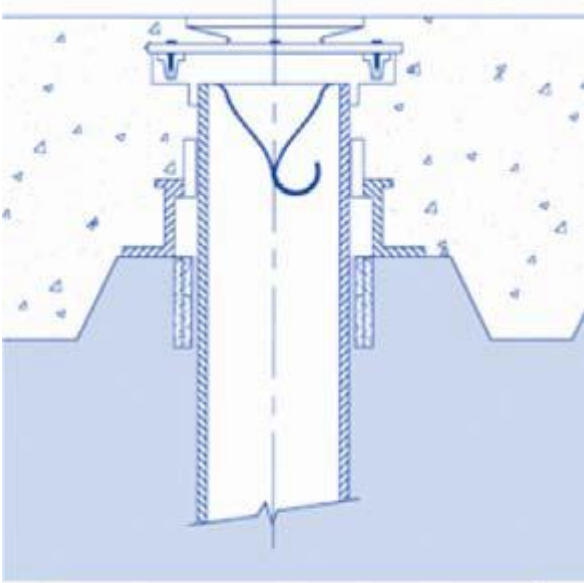
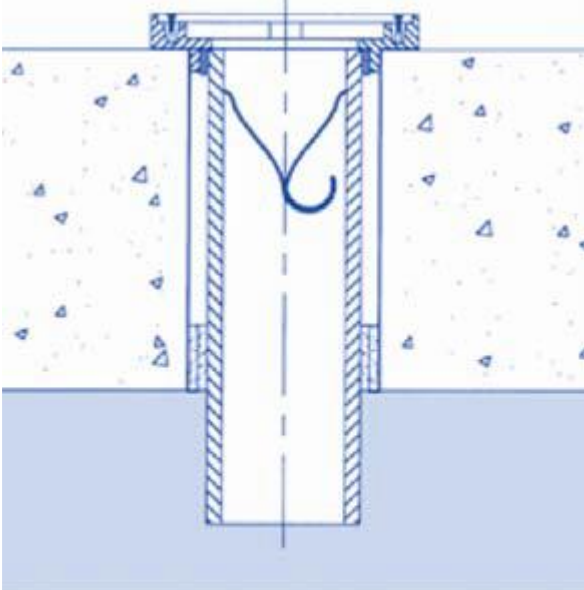
	<p>T3563H-F-CI-FU¹ TG33</p>	<p>Add FU for 2³/₈" X 3¹/₂" funnel top drain</p>
 <p data-bbox="186 913 678 1071">Connect to plastic pipe in metal deck floor slab</p>	<p>Model Number and Component</p>	<p>ProSet Trap Guard®- Description / Application</p>
	<p>T2563H-F-SSW-CM TG22</p>	<p>2" Adj. NB ED for plastic in corrugated metal floor</p>
	<p>T3563H-F-SSW-CM TG33</p>	<p>3" Adj. NB ED for plastic in corrugated metal floor</p>
	<p>T3563H-F-SSW-CM-FU¹ TG33</p>	<p>Add FU for 2³/₈" X 3¹/₂" funnel top drain</p>
 <p data-bbox="186 1711 678 1869">Connect to plastic pipe through cored floor slab</p>	<p>Model Number and Component</p>	<p>ProSet Trap Guard®- Description / Application</p>
	<p>T2563H-F-SSW-CH TG22</p>	<p>2" Adj. NB ED for plastic pipe through cored hole</p>
	<p>T3563H-F-SSW-CH TG33</p>	<p>3" Adj. NB ED for plastic pipe through cored hole</p>
	<p>T3563H-F-SSW-CH-FU¹ TG33</p>	<p>Add FU for 2³/₈" X 3¹/₂" funnel top drain</p>

¹All above drain numbers are for 3". For 2" change the first number to 2

TABLE 2—TYLER PIPE, WADE DIVISION MODELS

<u>Model Numbers</u>	<u>Description</u>
1090-2CI	2" TG fits inside 2" C.I. pipe
1090-3W STRAINER	3" TG fits inside 3" strainer tailpiece
1090-3CI	3" TG fits inside 3" C.I. pipe
1090-34W	3" TG fits inside 4" PVC or C.I. pipe
1090-2PVC	2" TG fits inside 2" PVC pipe
1090-3PVC	2" TG fits inside 3" PVC pipe
1090-34CI	3" TG fits inside 4" C.I. pipe