

BIDET SLEEVE ASSEMBLY

CONCRETE ON CORRUGATED METAL THROUGH FLOORS

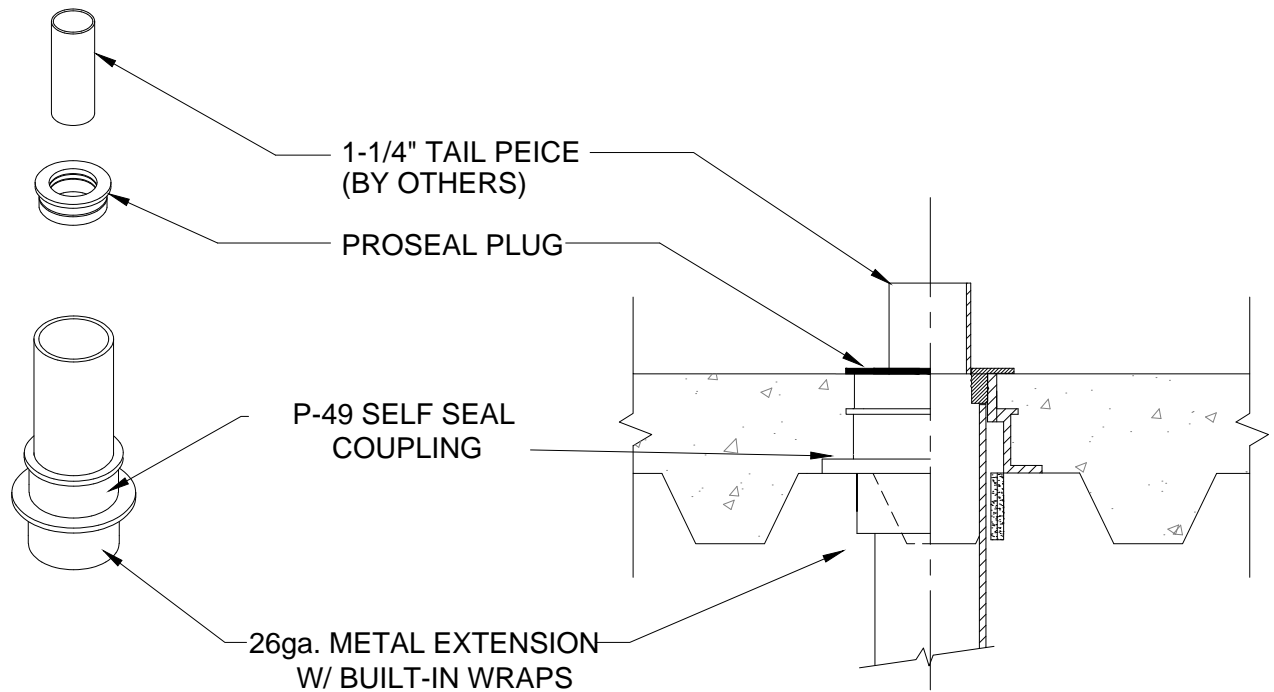

IMPORTANT NOTES :

1. Cut hole through the deck to accommodate the 26 ga. metal extension to the bottom of corrugations.
2. Mount sleeve to the corrugated metal with sheet metal screws, if necessary use a right angle metal strip to span the corrugations. See component drawing P-43CM.
3. After concrete is poured, connect the trap and branch pipe to the bottom of the sleeve coupling.
4. The bidet is connected by inserting the bidet tail piece into the C25660 ProSeal plug.



W.H. Directory Reference 97 Edition
Firestop Device
W.H. Design No. PS/PH 120-07
F Rating 2 Hrs.



PROSET[®]
SYSTEMS
FIRESTOP PENETRATOR™

DATE :
05-31-21

DRG . NO .
C-6610-C