

# TUB BOX SLEEVE ASSEMBLY

FOR SHALLOW CONCRETE FLOORS or CORRUGATED METAL

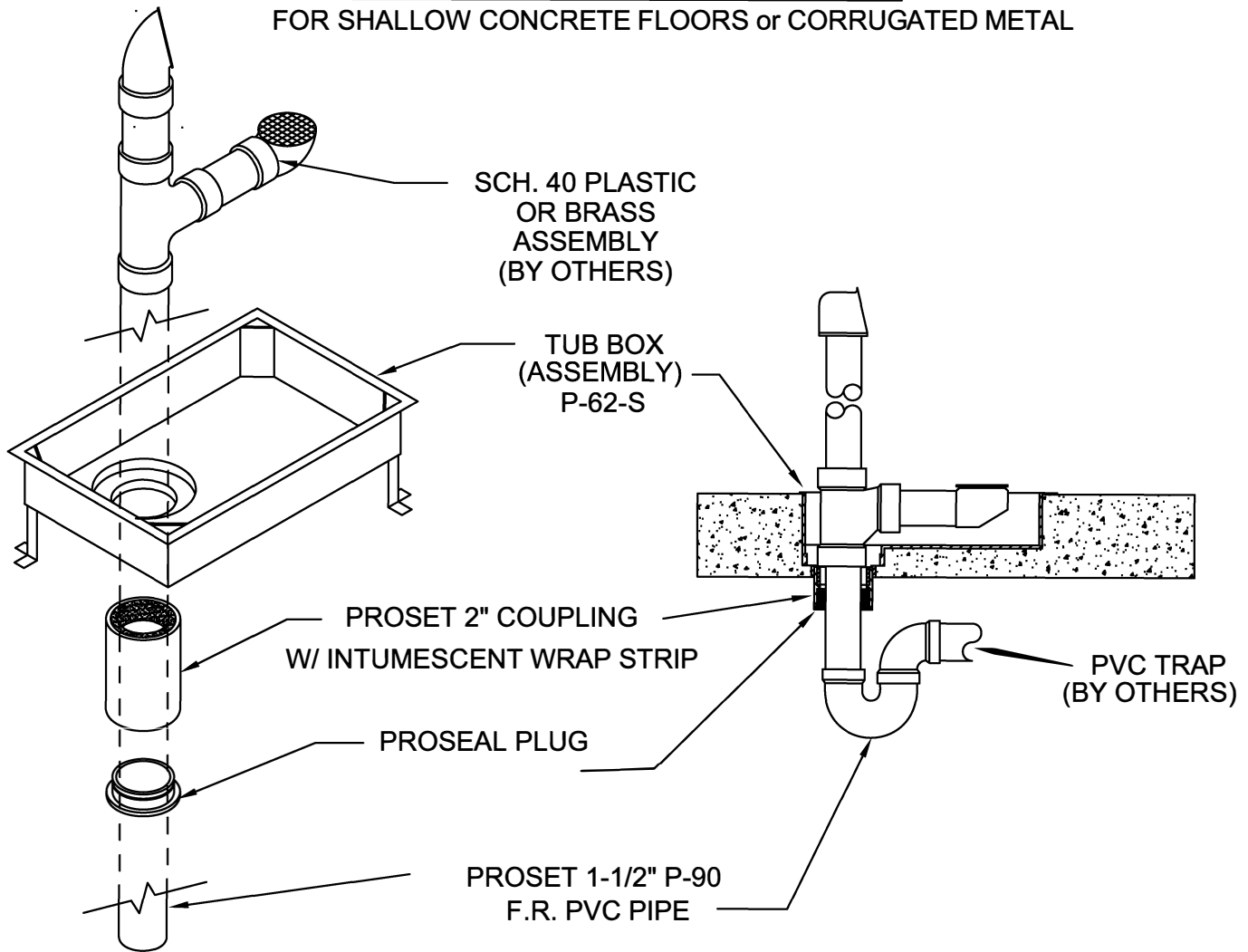

## IMPORTANT NOTES :

1. Use the proper height metal legs to secure the tub box with sheet metal screws & the legs to the floor deck with nails.
2. After the minimum 3" concrete pour, use the special ProSet PVC coupling extension with the built-in intumescent wrap strip, solvent welded into the box.
3. Pass a schedule 40 PVC waste & overflow pipe through the box and coupling using ProSet's P-90 PVC pipe through the floor.
4. Insert the P25661 ProSeal Plug into the bottom of the coupling around the P-90 pipe.
5. Complete the installation by installing the branch piping and trap to the P-90 pipe.

Note: Tub box can be used in concrete on top of corrugated metal decks.



W.H. Directory Reference 99 Edition  
Firestop Device  
W.H. Design No. PS/PH 120-10  
F Rating 2 Hrs.



**PROSET**<sup>®</sup>  
**SYSTEMS**  
FIRESTOP PENETRATOR™

DATE :

5-31-21

DRG . NO .

C-6211-A2