

# CORED HOLE PENETRATION

FOR CABLE AND WIRE  
FOR CORED HOLES THROUGH FLOORS

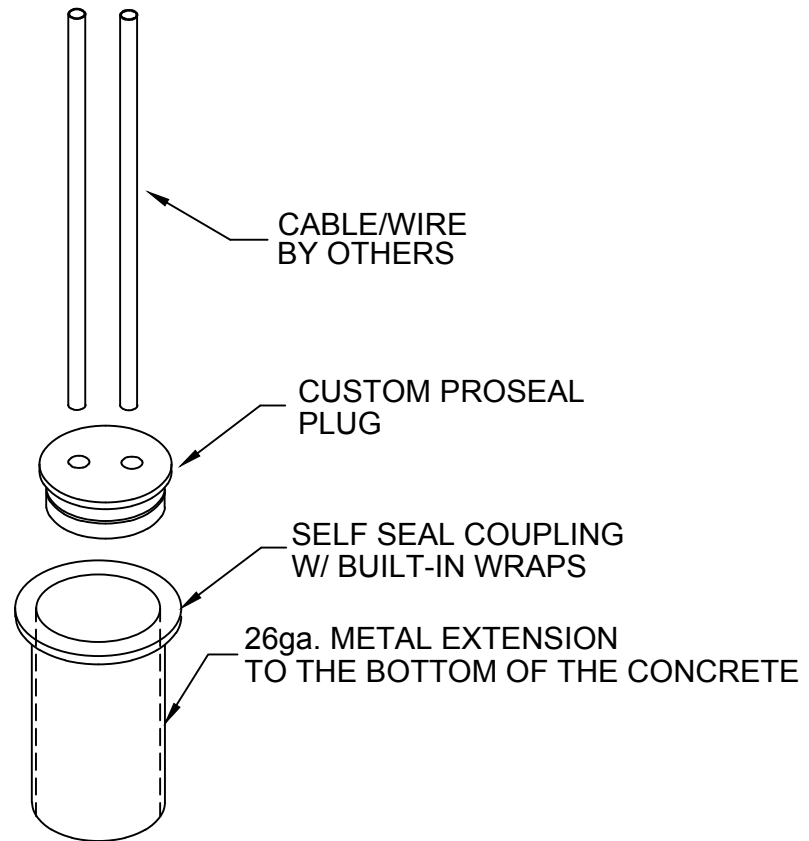

EXPLODED VIEW

## IMPORTANT NOTES :

1. Core 3" hole.
2. Install a bead of ProSet Caulk around the coupling flange to waterproof.
3. Insert pass through cable/wire up through the sleeve coupling.
4. Drill your own holes in ProSeal plug to accomodate cable or wire.
5. Install the custom size split ProSeal Plug around the cable/wire & insert into the sleeve coupling.
6. Use two ProSeal plugs for wall installations.
7. Penetrations used in a series must be spaced 2" apart side by side.



W.H. Directory Reference 99 Edition  
Firestop Device  
W.H. Design No. PS/PH 180-04  
F Rating 2 Hrs.



**PROSET**<sup>®</sup>  
**SYSTEMS**  
FIRESTOP PENETRATOR™

DATE :  
12-10-19  
DRG . NO .  
E-1003-D