

A Special Rubber Flexible Coupling Made For PVC DWV Plumbing Stacks

NEW

EXPANSION THAT MAKES SENSE

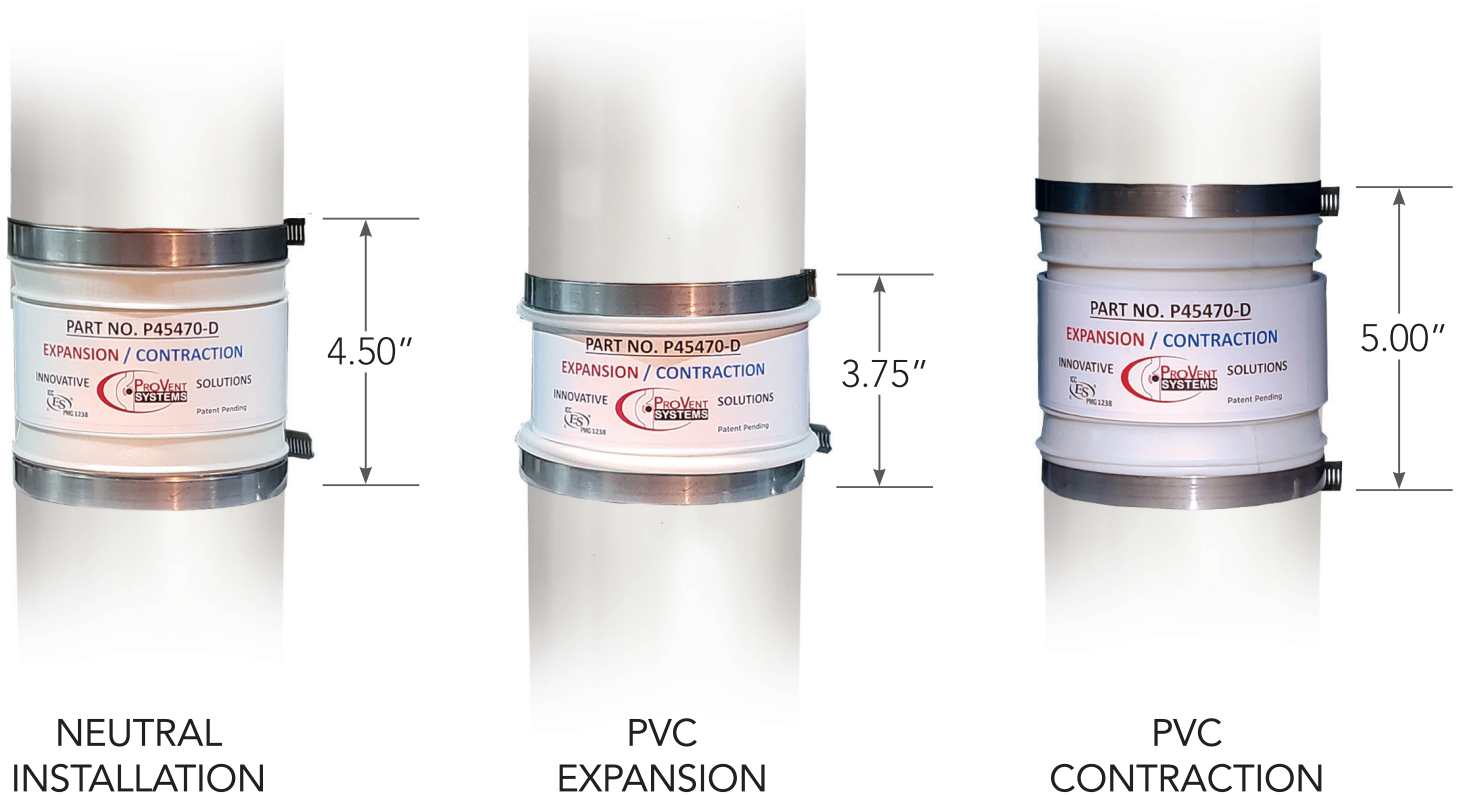

Most engineers use P.E. Thermal Expansion Charts to determine the overall movement of PVC pipe in a multi-story building. If the chart shows 3" movement within a 100 feet of vertical PVC pipe, most engineers would normally select one expansion joint that moves 3" and locate it near the top of the PVC pipe.

The above method does makes sense unless the PVC pipe is a DWV plumbing stack that has branches coming off at every floor. Then the

expansion should then be compensated at every floor or every other floor. Its here where branch pipe breakage could occur without using the right type of expansion fitting. This inexpensive ProVent Expansion Coupling can compensate up to 3/4" when needed. All four story or more apartment/hotel type buildings need this protection for both concrete and more importantly wood structures with a lot of shrinkage.



1355 Capital Circle, Lawrenceville, GA 30043
TEL: 800.262.5355 • FAX: 770.339.1784
www.proventsystems.com



EZ Flex Mechanical Coupling Installation Instructions

The EZ Flex Mechanical Coupling needs an anchor point in order to work as an expansion and contraction device for PVC or ABS DWV stacks. The anchor point can start with the horizontal underground piping, any secured pipe offset, or any 3" or 4" size horizontal branch securely fastened enough to act as an anchor, allowing the flex coupling device to move freely.

The Mechanical Coupling must fit and be installed in-between two connecting PVC stack pipes using an exact 2-1/2" or 2-3/4" space or void in order to provide either 1/2" or 3/4" expansion and contraction in-line movement up or down. Use primer with the dauber to take the gloss off the two PVC pipe ends for a better fit from the pipe to the coupling's flexible hubs.

Roll up the top and bottom flex portions of the coupling onto the rigid middle PVC section and insert the coupling inside the exact 2-1/2" or 2 3/4" space or pipe void.

The two connecting pipes must be in alignment with each other. If they don't align, one pipe must move in order to create the proper straight alignment.

After inserting the rolled up coupling into the void, roll back the two flex portions on the top and bottom back onto the two connecting pipes.

Before tightening the bands it's very important to adjust the two connecting pipes into the rubber coupling leaving equal spacing on both the top and the bottom pipes.

After adjusting the couplings space equally, tighten the 301 stainless steel bands on both the top and bottom using a 60 lb. torque driver.

Recommended Flex Coupling Uses and Locations:

Mechanical Flex Couplings can be used to facilitate prefabbed piping into penetrations.

Mechanical Flex Water Tester can be used alternately to water test the stack piping.

The number of Flex Couplings used for expansion can change with the type of construction being used. Recommended spacing of expansion couplings for concrete structures would start at the third floor then continue up every other floor until the second highest floor.

Wood construction should consider both the expansion of plastic piping plus the structural wood settlement that occurs inside the building. Shrinkage in light frame construction can range from 0.05 to 0.5 inch per level. Recommend using one on the first, second & third floors in 3 and 4 stories, then every other floor up to the second highest floor in higher buildings.

ProVent Systems 1355 Capital Circle, Lawrenceville, GA. 30043 Phone: 800-262-5355

EZ Flex Mechanical Installation Instructions

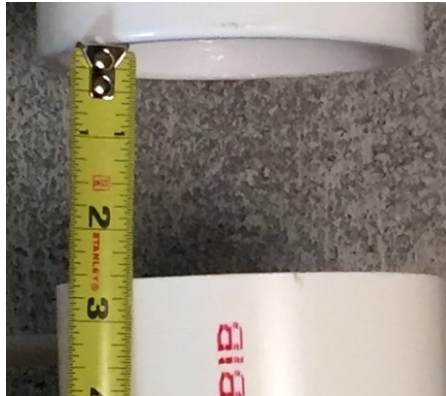

Insert a 2-1/2" gap between the pipes

1.



Insert the rolled up ends into the gap

3.



Tighten up the stainless steel bands

5.



See other page instructions



Roll both flex ends to meet each other

2.

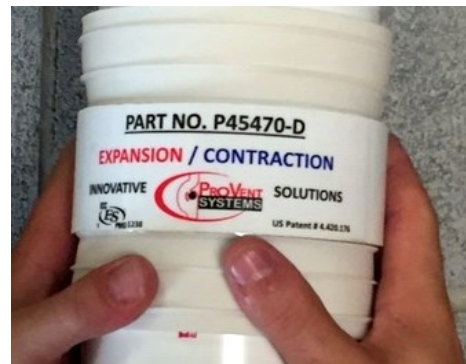

Roll back two ends back onto the pipes

4.



EZ flex joint flexes vertical and horizontal

6.



1355 Capital Circle, Lawrenceville, GA. 30043

800-262-5355 Fax: 770-339-1784

www.proventsystems.com

EZ Flex Mechanical Coupling

Tapered Flex Rubber Permits a Smooth Waste Water Flow

Complies With ICC ES-PMG-1238 And IAPMO IGC-359

FLEXIBLE COUPLING
MATERIAL SANOPRENE
TM# 8211-45

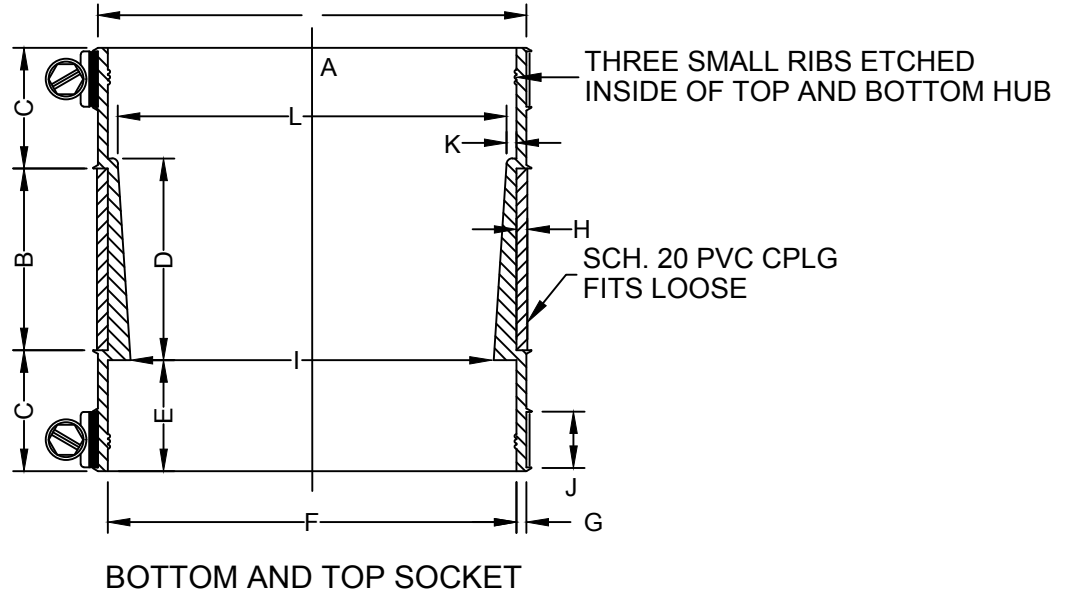

Dimensions, in (mm)												
	A	B	C	D	E	F	G	H	I	J	K	L
3"	3.720 (94.49)	2.000 (50.80)	1.260 (32.00)	2.220 (56.39)	1.220 (30.99)	3.500 (88.90)	0.110 (2.79)	0.120 (3.05)	3.000 (76.20)	0.575 (14.60)	0.110 (2.79)	3.280 (83.31)
4"	4.720 (119.90)	2.000 (50.80)	1.260 (32.00)	2.220 (56.39)	1.220 (30.99)	4.500 (114.00)	0.110 (2.79)	0.120 (3.05)	4.000 (101.60)	0.575 (14.60)	0.110 (2.79)	4.280 (108.70)

Uniform Plumbing Code Section 312.2 states: All plumbing piping shall be so installed that the piping or connections will not be subject to undue strains or stresses. **Section 705.9.2 states:** Expansion joints shall be accessible, except when used for DWV stacks,

EXPANSION / CONTRACTION

SPECIALLY MADE FOR PVC/ABS DWV PLUMBING STACKS

US PATENT NO. 9,982,823

