

FIRE GUARD BOX FOR MIXING VALVES

FOR TUB & SHOWER VALVES IN A FIRE RATED WALL

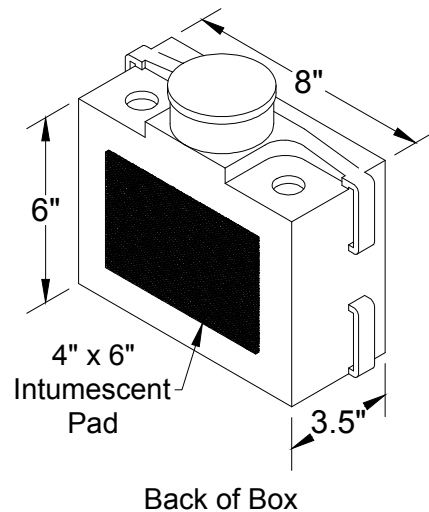
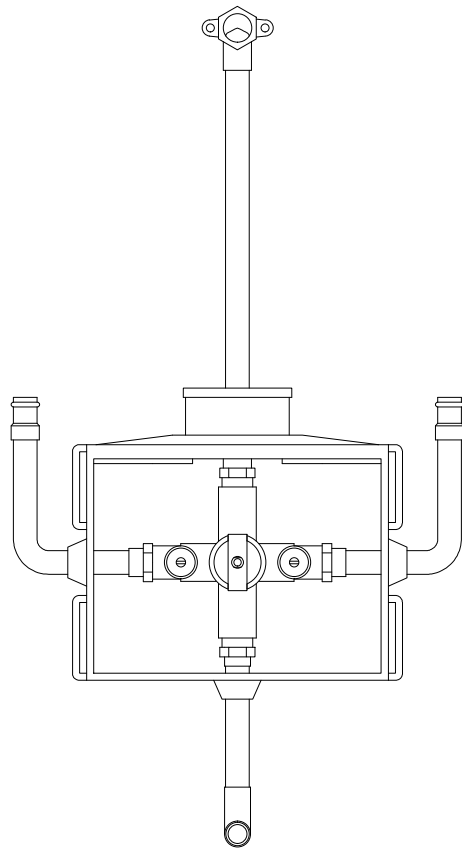

IMPORTANT NOTES :

1. Secure the valve box using a suitable metal support system to the stud walls.
2. Use 1/2" copper pipe to connect the mixing valve inside the box.
3. Drill 5/8" holes through the box at the desired locations to connect the piping to the valve.
4. Close off the 2" top or bottom PVC opening using a blank tapped ProSeal Plug.
5. Seal off any unused openings by applying fire rated caulking or putty.
6. Final connections can be made with proper adapters to any approved piping.

Reversing the valve box installation is optional



W.H. Directory Reference 05 Edition
Firestop Device
W.H. Design No. PS/PV 120-08
F Rating 1 Hr. or 2 Hrs. Walls



PROSET[®]
SYSTEMS
FIRESTOP PENETRATOR™

DATE :
05-31-21

DRG . NO .
C-8121-F