

TUB BOX SLEEVE ASSEMBLY

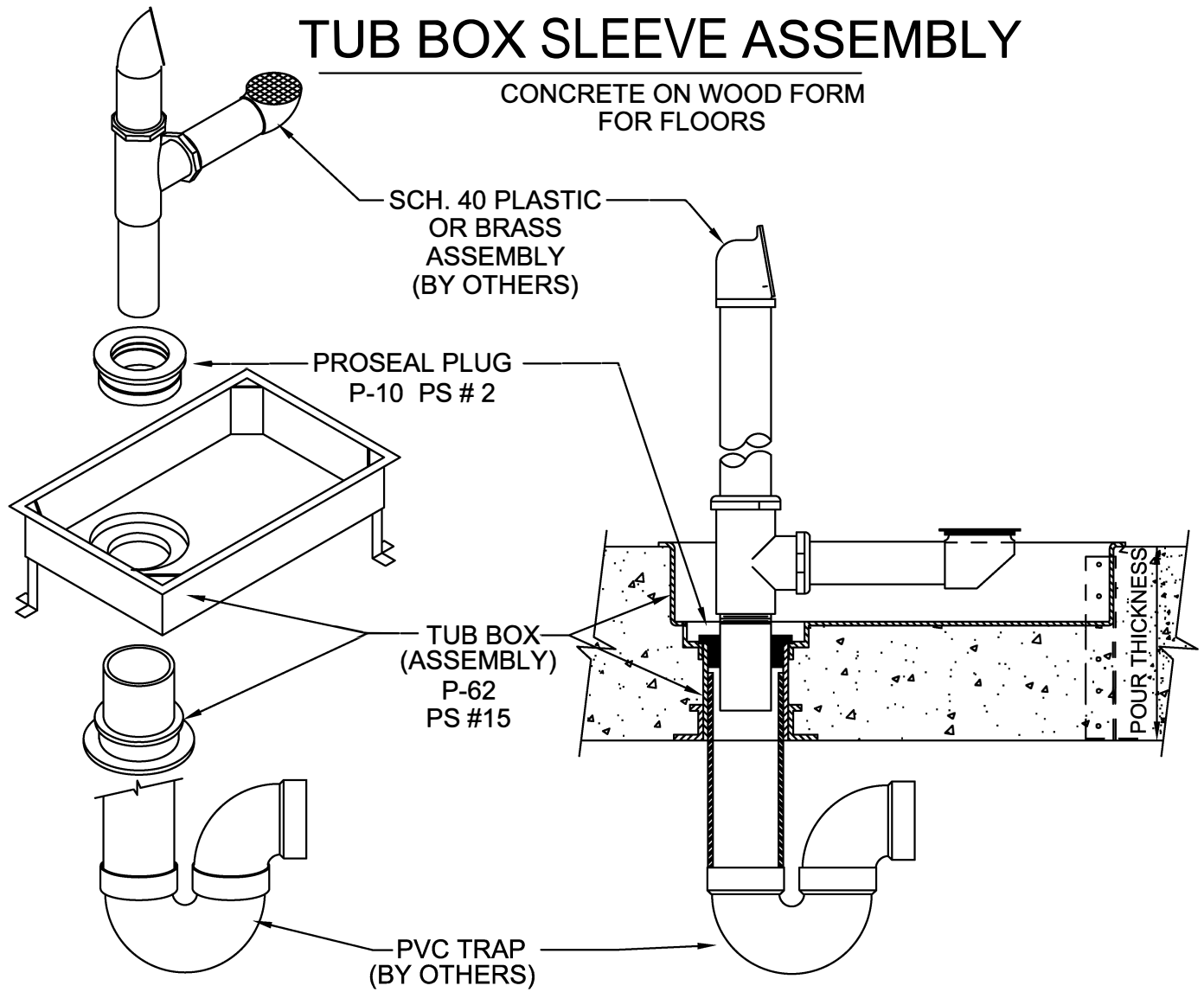

IMPORTANT NOTES :

1. Insert the proper size support legs & solvent cement the Sleeve Coupling to the tub box socket.
2. Use nails through the leg & flange holes to mount box to deck.
3. After the concrete pour and before setting tub, remove styrofoam and knock out test cap.
Use a 1-1/2" plastic or brass waste & overflow and drop through the ProSeal Plug into the sleeve.
4. Use the P-25661 (pipe size) or P-25662 (tube size) ProSeal Plug to seal the top of sleeve.
5. Connect the vertical piping and the 2" or 1 1/2" PVC P-Trap to the 2" coupling at the bottom of the box.

Important: The above installation drawing can only be used when the concrete slab is 7" or more.
When the concrete floor depth is less than 7", refer to Drawing No. C-6211-A for different installation instructions.



W.H. Directory Reference 04 Edition
Firestop Device
W.H. Design No. PS/PH 120-17
F Rating 2 Hrs.



PROSET[®]
SYSTEMS
FIRESTOP PENETRATOR™

DATE :

5.31.21

DRG . NO .

C-6212-A