

FLOOR DRAIN W/FUNNEL ASSEMBLY

FOR CONCRETE FLOOR ON WOOD OR STEEL FORM

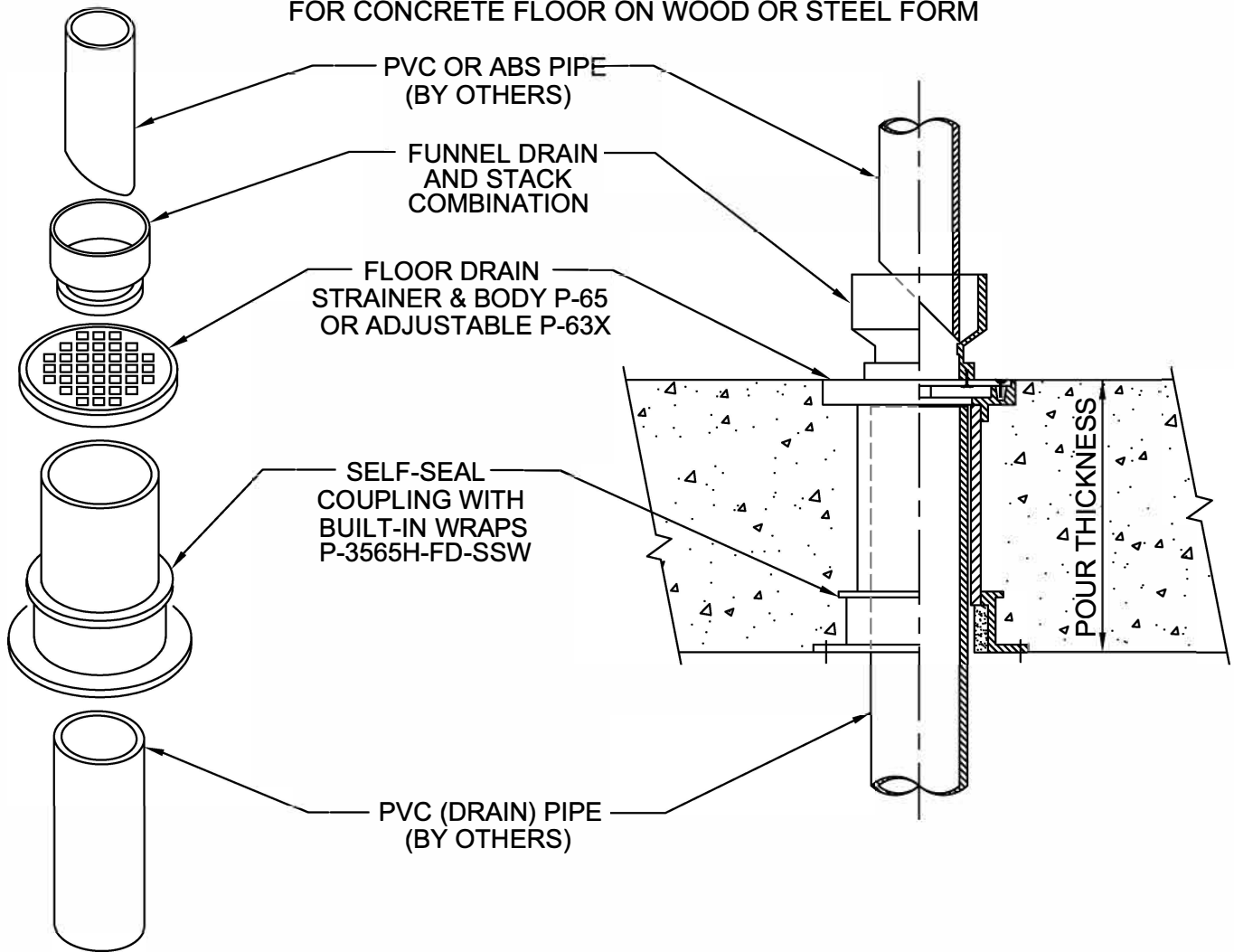

Size	Part No.	Description	Price
2"	P2565H-FD-SSW	2" Floor Drain w/funnel & wrap	84.80
3"	P3565H-FD-SSW	3" Floor Drain w/funnel & wrap	103.50
4"	P4565H-FD-SSW	4" Floor Drain w/funnel & wrap	124.50



W.H. Directory Reference 97 Edition
Firestop Device
W.H. Design No. PS/PH 120-07
F Rating 2 Hrs.



PROSET[®]
SYSTEMS
FIRESTOP PENETRATOR™

DATE :
5-31-21
DRG . NO .
C-6510FD-Ap