

# FLOOR DRAIN W/FUNNEL ASSEMBLY

FOR CONCRETE FLOOR ON WOOD OR STEEL FORM

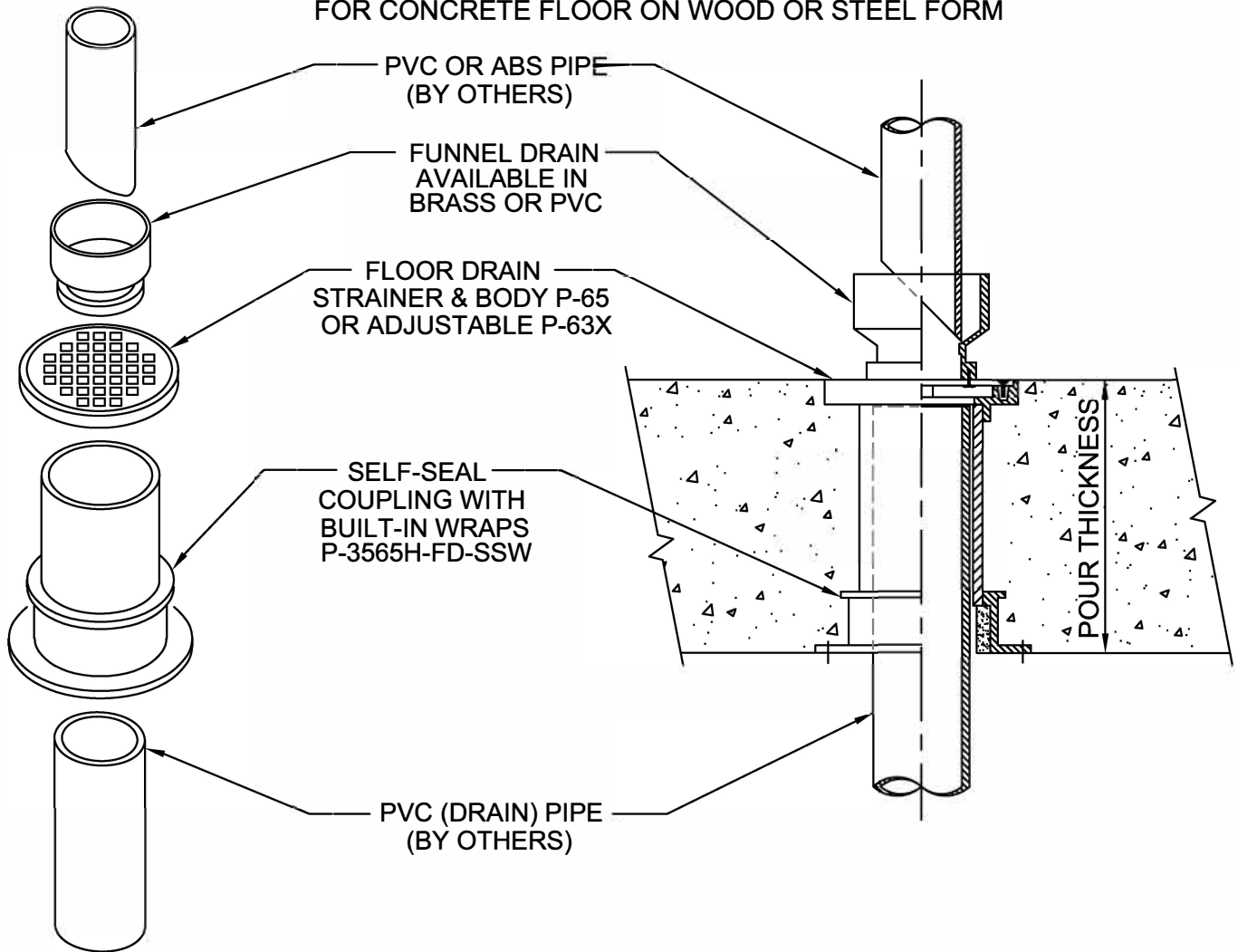

## IMPORTANT NOTES:

1. Order floor drain stub height 1/2" shorter to reflect concrete pitch to the drain.
2. Use nails through the flange holes to mount the self seal stub to the deck.
3. Solvent cement the drain top base onto the top of the drain stub.
4. Use duck tape over the top of strainer base to protect from concrete pour
5. After the concrete pour, install the strainer with the funnel drain. Insert the angle cut plastic stack pipe into the funnel, then solvent cement the top portion of the stack into the above drain stub. This makes the combination stack and area drain without using a separate stack and a separate drain.



W.H. Directory Reference 97 Edition  
Firestop Device  
W.H. Design No. PS/PHV 180-03  
F Rating 3 Hrs.



**PROSET**<sup>®</sup>  
**SYSTEMS**  
FIRESTOP PENETRATOR™

DATE :  
5-31-21

DRG. NO.  
C-6510FD-A