

SELF SEAL SHOWER/FLOOR DRAIN ASSEMBLY

CONCRETE ON CORRUGATED METAL DECK
FOR FLOORS

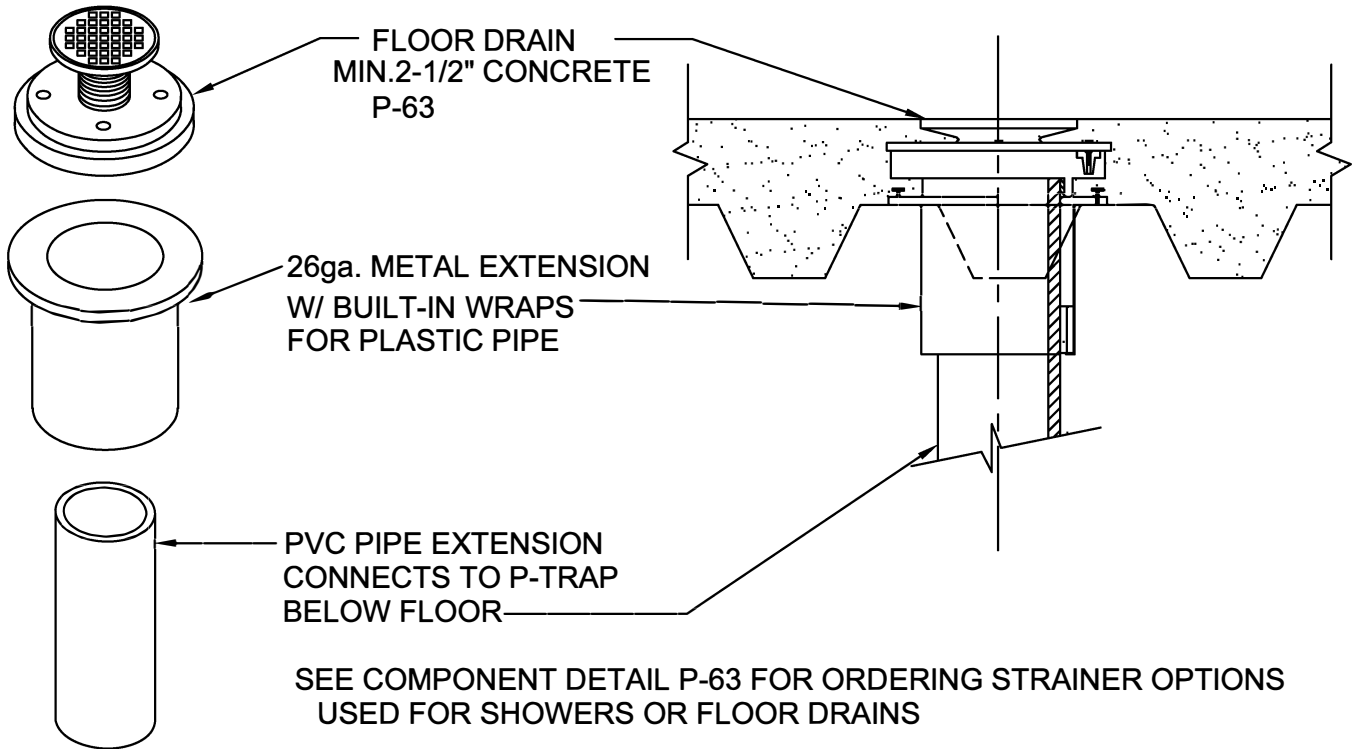

Size	Part No.	Description	Price
2"	P2563H-S or F-SSW-CM	2" NB Floor Drain With built-in Wrap Strips	63.85
3"	P3563H-S or F-SSW-CM	3" NB Floor Drain With built-in Wrap Strips	76.45
4"	P4563H-S or F-SSW-CM	4" NB Floor Drain With built-in Wrap Strips	81.30



W.H. Directory Reference 98 Edition
Firestop Device
W.H. Design No. PS/PH 120-14
F Rating 2 Hrs.



PROSET[®]
SYSTEMS
FIRESTOP PENETRATOR™

DATE :
5-31-21

DRG . NO .
C-6332-Cp