

RISER CLAMP DEVICE

FOR 2 HR. GYPSUM WALLS

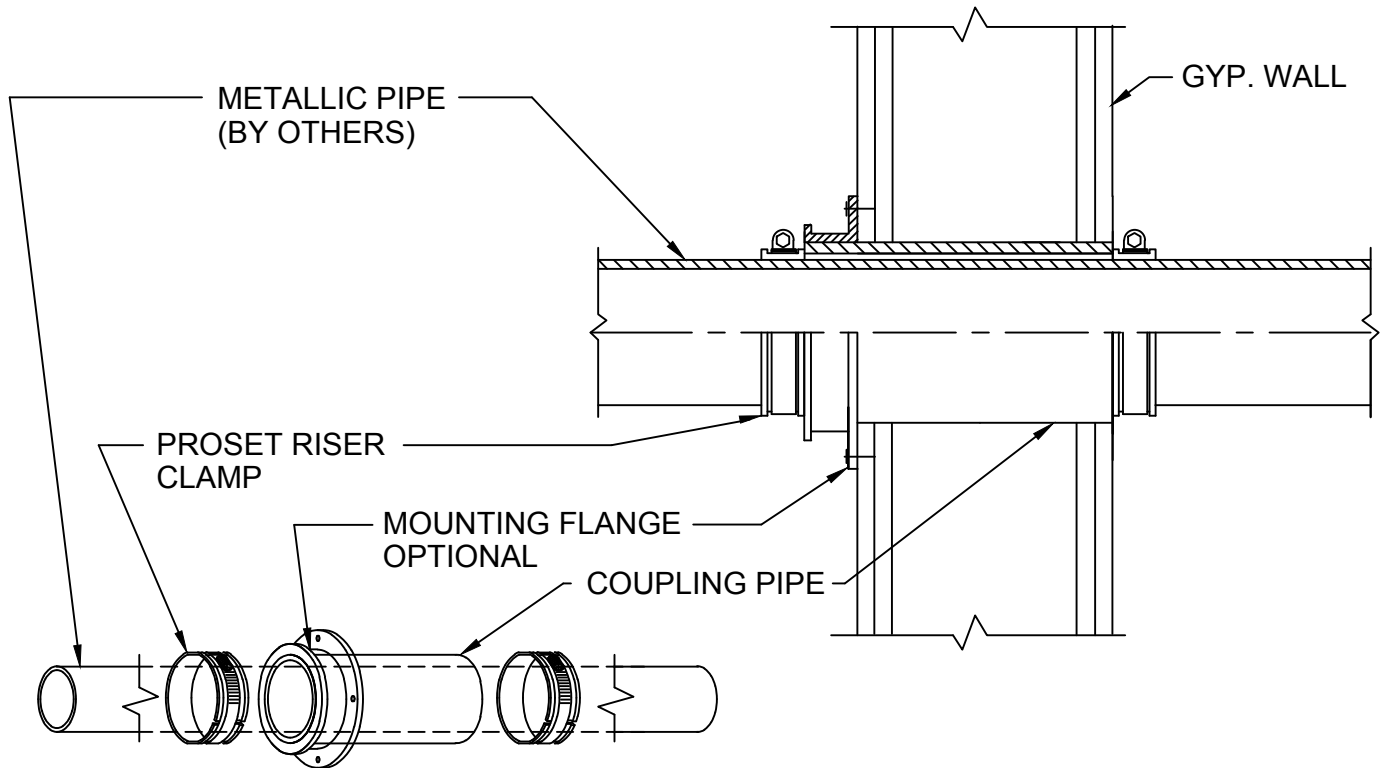

Size	Part No.	Description	Price	Unit Total
2"	P2543H-B or G-GW	2" Sleeve Coupling	6.95	12.85
	A02214 (2)	2" Riser Clamp	5.90	
2½"	P3843H- GW	2½" Sleeve Coupling	11.55	19.25
	A03212 (2)	2½" Riser Clamp	7.70	
3"	P3543H- B or G-GW	3" Sleeve Coupling	9.55	16.15
	A03214 (2)	3" Riser Clamp	6.60	
4"	P4543H- B or G-GW	4" Sleeve Coupling	12.40	20.70
	A04214 (2)	4" Riser Clamp	8.30	
5"	P6843H-GW	5" Sleeve Coupling	27.25	40.45
	A05214 (2)	5" Riser Clamp	13.20	
6"	P6543H-GW	6" Sleeve Coupling	19.70	33.20
	A06214 (2)	6" Riser Clamp	13.50	

Use "B" Black letter sleeve pipe for cast iron, glass or steel or "G" Green for copper or plastic
 Use suffix CU for copper -CI for cast iron -S for steel pipe when ordering Riser Clamps.



W.H. Directory Reference 97 Edition
 Firestop Device
 W.H. Design No. PS/PV 120-01
 F Rating 2 Hrs.



PROSET[®]
SYSTEMS
 FIRESTOP PENETRATOR™

DATE :
 8-01-18
 DRG . NO .
 A-1015-F